

12/10/2025 4:41 PM
 c:\users\julianarodriguez\building_drops, inc\building_drops_projects\odl, inc\bc-25-0439_1 - submittal - odl fiberglass doors component additions\dwg\glazed\odl012.dwg

ELEVATION OXO CONFIGURATION

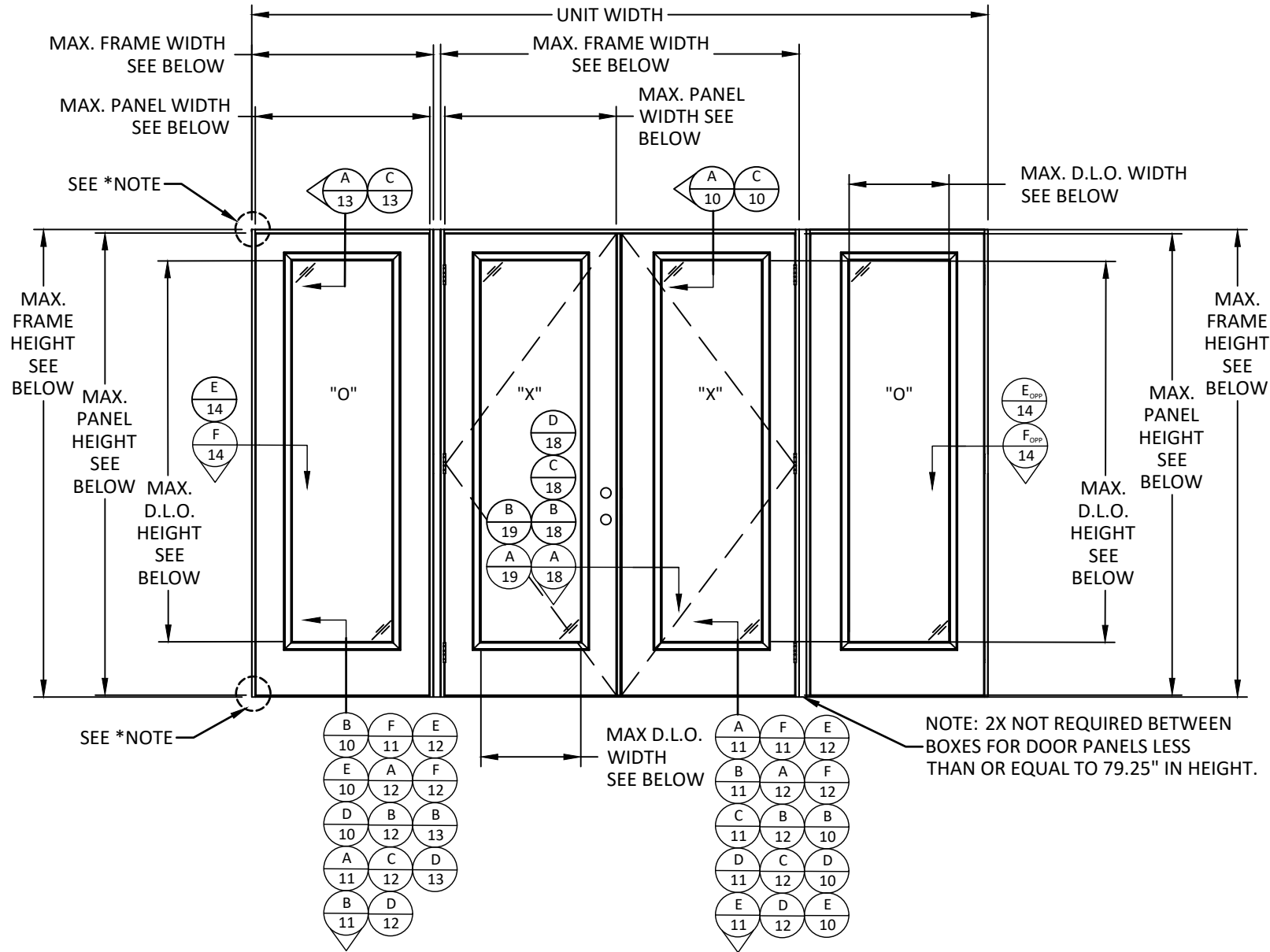

NOTE: BOXED CONSTRUCTION SHOWN, CONTINUOUS CONSTRUCTION QUALIFIED. SEE SHEETS 15-17 FOR HORIZONTAL SECTION DETAILS FOR CONTINUOUS CONSTRUCTION.

*NOTE: OPTION TO ATTACH FRAME CORNERS WITH 7/16" X 2" 16 GAGE STAPLES WITH (4) PER CORNER ON THE HEAD AND (2) PER CORNER ON THE SILL. ANOTHER OPTION IS TO FASTEN EACH CORNER WITH #9 X 2-1/2" PHILLIPS HEAD SCREWS WITH (3) PER CORNER ON THE HEAD FOR ALL SILLS. FOR ENDURA AND DLP ADA SILLS, (3) SCREWS PER CORNER ON THE SILL. ALL OTHER SILLS CAN HAVE (2) SCREWS PER CORNER.



215 EAST ROOSEVELT AVE.
ZEELAND, MICHIGAN 49464
PH: (800) 253-3900

TITLE: INSWING & OUTSWING GLAZED FIBERGLASS DOOR (NON-HVHZ) (NON-IMPACT) OXO ELEVATION

PREPARED BY: BUILDING DROPS, INC.
1900 NE MIAMI CT. SUITE 2-15
MIAMI, FL 33132
PH: (954) 399-8478
FAX: (954) 744-4738
WEB: www.buildingdrops.com



REMARKS	BY	DATE

THE INSTALLATION DETAILS DESCRIBED HEREIN ARE GENERIC AND MAY NOT REFLECT ACTUAL CONDITIONS FOR A SPECIFIC SITE. IF SITE CONDITIONS CAUSE INSTALLATION TO DEVIATE FROM THE REQUIREMENTS DETAILED HEREIN, A LICENSED ENGINEER OR ARCHITECT SHALL PREPARE SITE SPECIFIC DOCUMENTS FOR USE WITH THIS DOCUMENT.



HERMES F. NORERO
LICENSE
No. 73778
STATE OF FLORIDA
PROFESSIONAL ENGINEER
HERMES F. NORERO, R.
1900 NE MIAMI CT. SUITE 2-15
MIAMI, FL 33132
FBPE CERT. OF AUTHORIZATION No. 29578

FL #: **FL47925**

DATE: **12.01.2025**

DWG. BY: **JR** CHK. BY: **HFN**

SCALE: **NTS**

DWG. #: **ODL012**

SHEET: **4** OF 25

PRODUCT	MAX. SIDELITE FRAME WIDTH (IN)	MAX. SIDELITE FRAME HEIGHT (IN)	MAX. SIDELITE PANEL WIDTH (IN)	MAX. SIDELITE PANEL HEIGHT (IN)	MAX. SIDELITE D.L.O. WIDTH (IN)	MAX. SIDELITE D.L.O. HEIGHT (IN)
6'8" GLAZED	37.50	82.00	35.75	79.25	20.90	62.88
8'0" GLAZED	37.50	98.00	35.75	95.25	20.90	78.88

PRODUCT	MAX. DOOR FRAME WIDTH (IN)	MAX. DOOR FRAME HEIGHT (IN)	MAX. DOOR PANEL WIDTH (IN)	MAX. DOOR PANEL HEIGHT (IN)	MAX. DOOR D.L.O. WIDTH (IN)	MAX. DOOR D.L.O. HEIGHT (IN)
6'8" GLAZED	74.50	82.00	35.75	79.25	20.90	62.88
8'0" GLAZED	74.50	98.00	35.75	95.25	20.90	78.88

c:\users\julianarodriguez\building_drops, inc\building_drops\glazed\odl012.dwg - submittal - odl fiberglass doors component additions\dwgs\glazed\odl012.dwg 12/10/2025 4:41 PM

ELEVATION OXO CONFIGURATION

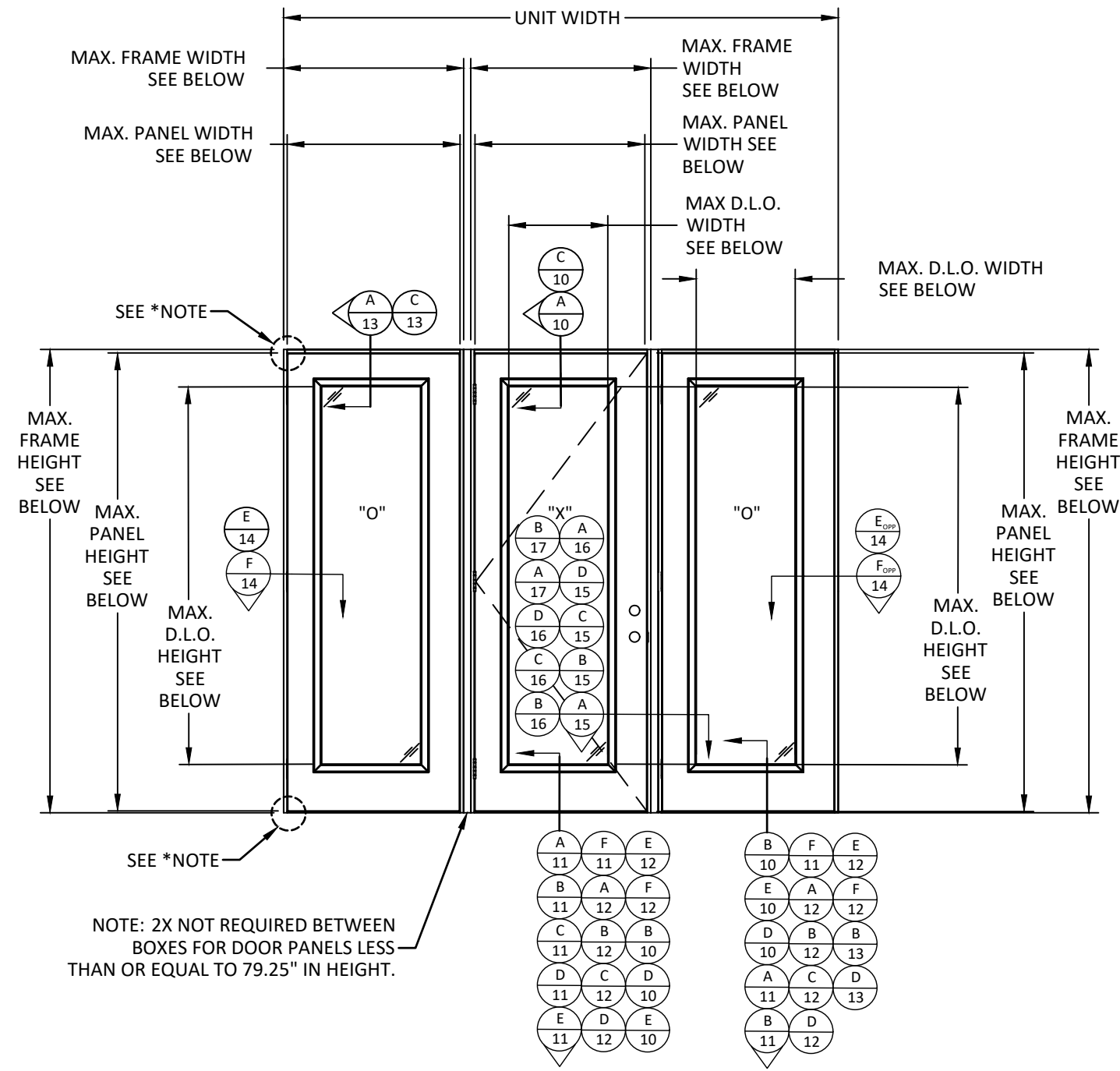

NOTE: BOXED CONSTRUCTION SHOWN, CONTINUOUS CONSTRUCTION QUALIFIED. SEE SHEETS 15-17 FOR HORIZONTAL SECTION DETAILS FOR CONTINUOUS CONSTRUCTION.

*NOTE: OPTION TO ATTACH FRAME CORNERS WITH 7/16" X 2" 16 GAGE STAPLES WITH (4) PER CORNER ON THE HEAD AND (2) PER CORNER ON THE SILL. ANOTHER OPTION IS TO FASTEN EACH CORNER WITH #9 X 2-1/2" PHILLIPS HEAD SCREWS WITH (3) PER CORNER ON THE HEAD FOR ALL SILLS. FOR ENDURA AND DLP ADA SILLS, (3) SCREWS PER CORNER ON THE SILL. ALL OTHER SILLS CAN HAVE (2) SCREWS PER CORNER.



215 EAST ROOSEVELT AVE.
ZEELAND, MICHIGAN 49464

PH: (800) 253-3900

TITLE: INSWING & OUTSWING GLAZED FIBERGLASS DOOR (NON-HVHZ) (NON-IMPACT)
OXO ELEVATION

PREPARED BY: BUILDING DROPS, INC.
1900 NE MIAMI CT. SUITE 2-15
MIAMI, FL 33132
PH: (954) 399-8478
FAX: (954) 744-4738
WEB: www.buildingdrops.com

REMARKS	BY	DATE

THE INSTALLATION DETAILS DESCRIBED HEREIN ARE GENERIC AND MAY NOT REFLECT ACTUAL CONDITIONS FOR A SPECIFIC SITE. IF SITE CONDITIONS CAUSE INSTALLATION TO DEVIATE FROM THE REQUIREMENTS DETAILED HEREIN, A LICENSED ENGINEER OR ARCHITECT SHALL PREPARE SITE SPECIFIC DOCUMENTS FOR USE WITH THIS DOCUMENT.

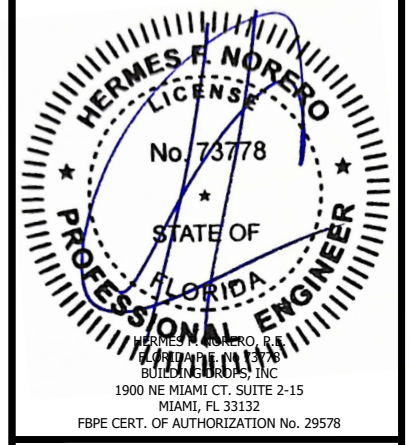

FL #: **FL47925**

DATE: **12.01.2025**

DWG. BY: **JR** CHK. BY: **HFN**

SCALE: **NTS**

DWG. #: **ODL012**

SHEET: **5**
OF 25

SIDLITE: PRODUCT DIMENSIONS TABLE

PRODUCT	MAX. SIDELITE FRAME WIDTH (IN)	MAX. SIDELITE FRAME HEIGHT (IN)	MAX. SIDELITE PANEL WIDTH (IN)	MAX. SIDELITE PANEL HEIGHT (IN)	MAX. SIDELITE D.L.O. WIDTH (IN)	MAX. SIDELITE D.L.O. HEIGHT (IN)
6'8" GLAZED	37.50	82.00	35.75	79.25	20.90	62.88
8'0" GLAZED	37.50	98.00	35.75	95.25	20.90	78.88

DOOR: PRODUCT DIMENSIONS TABLE

PRODUCT	MAX. DOOR FRAME WIDTH (IN)	MAX. DOOR FRAME HEIGHT (IN)	MAX. DOOR PANEL WIDTH (IN)	MAX. DOOR PANEL HEIGHT (IN)	MAX. DOOR D.L.O. WIDTH (IN)	MAX. DOOR D.L.O. HEIGHT (IN)
6'8" GLAZED	37.50	82.00	35.75	79.25	20.90	62.88
8'0" GLAZED	37.50	98.00	35.75	95.25	20.90	78.88

12/10/2025 4:41 PM
 c:\users\julianarodriguez\building_drops, inc\building_drops, inc\documents\common\projects\odl, inc\bc-25-0439_1 - submittal - odl_fiberglass doors component additions\dwg\glazed\odl012.dwg

ELEVATION XX CONFIGURATION

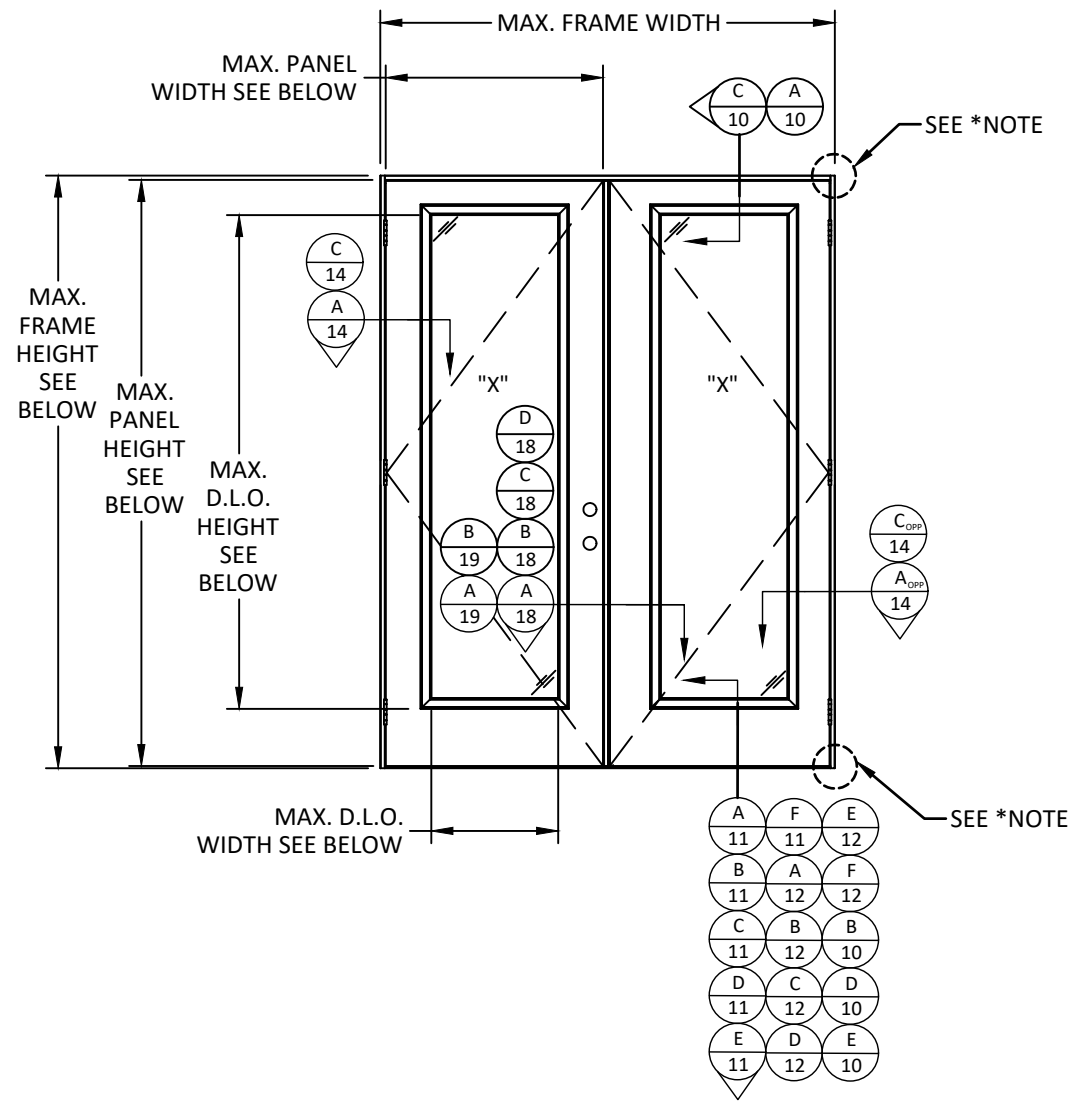

ELEVATION X CONFIGURATION

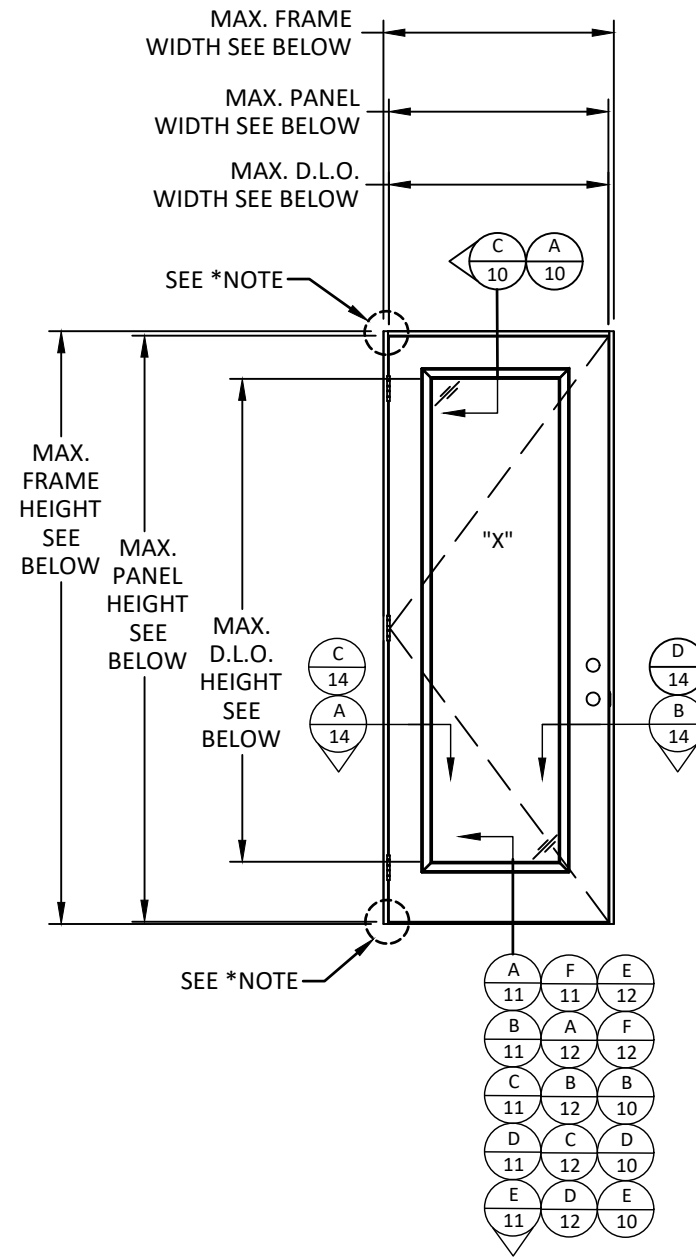

*NOTE: OPTION TO ATTACH FRAME CORNERS WITH 7/16" X 2" 16 GAGE STAPLES WITH (4) PER CORNER ON THE HEAD AND (2) PER CORNER ON THE SILL. ANOTHER OPTION IS TO FASTEN EACH CORNER WITH #9 X 2-1/2" PHILLIPS HEAD SCREWS WITH (3) PER CORNER ON THE HEAD FOR ALL SILLS. FOR ENDURA AND DLP ADA SILLS, (3) SCREWS PER CORNER ON THE SILL. ALL OTHER SILLS CAN HAVE (2) SCREWS PER CORNER.

DOOR: PRODUCT DIMENSIONS TABLE						
PRODUCT	MAX. DOOR FRAME WIDTH (IN)	MAX. DOOR FRAME HEIGHT (IN)	MAX. DOOR PANEL WIDTH (IN)	MAX. DOOR PANEL HEIGHT (IN)	MAX. DOOR D.L.O. WIDTH (IN)	MAX. DOOR D.L.O. HEIGHT (IN)
6'8" GLAZED	74.50	82.00	35.75	79.25	20.90	62.88
8'0" GLAZED	74.50	98.00	35.75	95.25	20.90	78.88



215 EAST ROOSEVELT AVE.
ZEELAND, MICHIGAN 49464
PH: (800) 253-3900

TITLE: INSWING & OUTSWING GLAZED FIBERGLASS DOOR (NON-HVHZ) (NON-IMPACT)
 X & XX ELEVATIONS

PREPARED BY: BUILDING DROPS, INC.
 1900 NE MIAMI CT, SUITE 2-15
 MIAMI, FL 33132
 PH: (954) 399-8478
 FAX: (954) 744-4738
 WEB: www.buildingdrops.com

REMARKS	BY	DATE

THE INSTALLATION DETAILS DESCRIBED HEREIN ARE GENERIC AND MAY NOT REFLECT ACTUAL CONDITIONS FOR A SPECIFIC SITE. IF SITE CONDITIONS CAUSE INSTALLATION TO DEVIATE FROM THE REQUIREMENTS DETAILED HEREIN, A LICENSED ENGINEER OR ARCHITECT SHALL PREPARE SITE SPECIFIC DOCUMENTS FOR USE WITH THIS DOCUMENT.

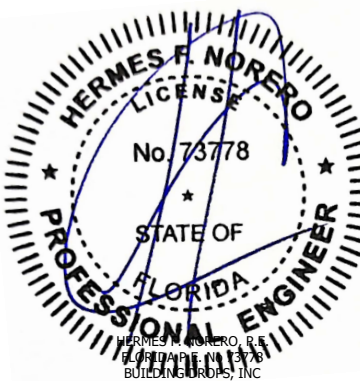

HERMES F. NORERO, R.
ENGINEER
BUILDING DROPS, INC.
1900 NE MIAMI CT, SUITE 2-15
MIAMI, FL 33132
FBPE CERT. OF AUTHORIZATION No. 29578

FL #: **FL47925**

DATE: **12.01.2025**

DWG. BY: **JR** CHK. BY: **HFN**

SCALE: **NTS**

DWG. #: **ODL012**

SHEET: **6** OF 25

c:\Users\julianarodriguez\building_drops, inc\building_drops_landing - documents\common\projects\odl, inc\bc-25-0439_1 - submittal - odl fiberglass doors component additions\dwgs\glazed\odl012.dwg 12/10/2025 4:42 PM

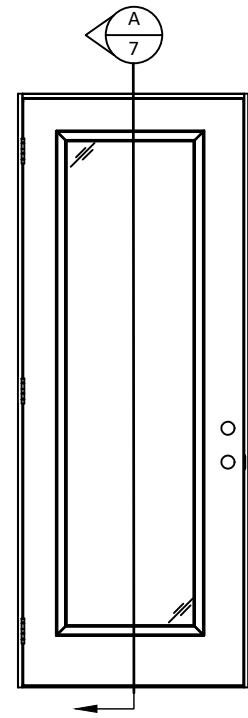

ELEVATION
DOOR / SIDELITE PANEL

NOTE: EVOLVE FRAME QUALIFIED FOR ALL CONFIGURATIONS AND SILL TYPES.

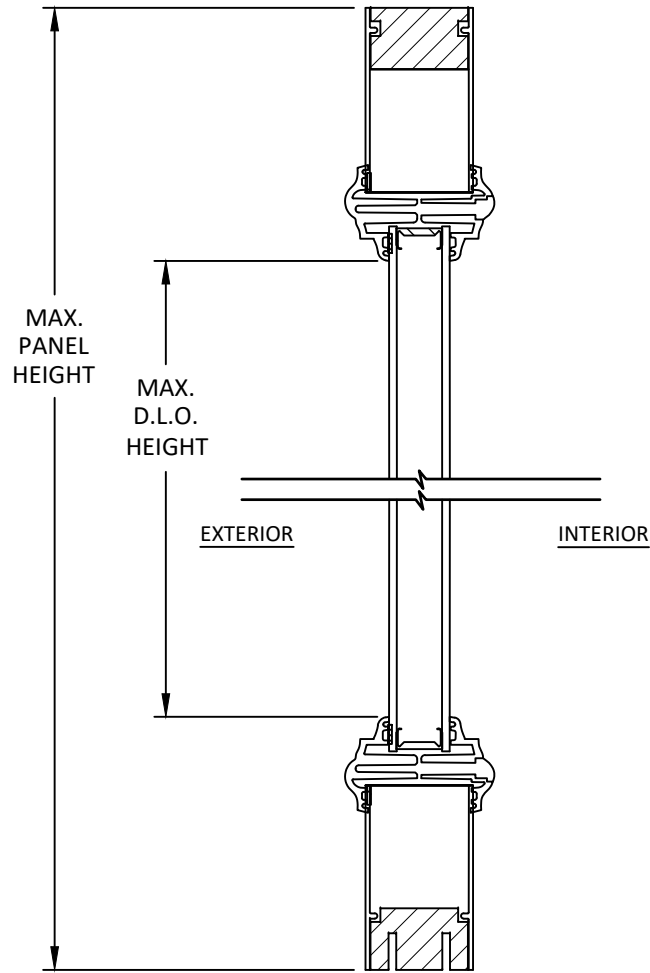

A-7 **VERTICAL SECTION**
EVOLVE FRAME

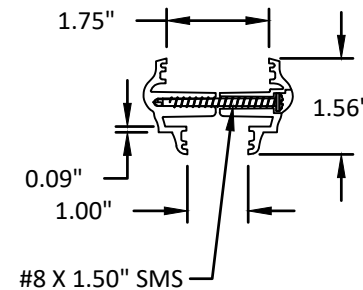

215 EAST ROOSEVELT AVE.
ZEELAND, MICHIGAN 49464

PH: (800) 253-3900

TITLE: **INSWING & OUTSWING GLAZED FIBERGLASS DOOR (NON-HVHZ) (NON-IMPACT)**
LITE KIT DETAILS

PREPARED BY: **BUILDING DROPS, INC.**

1900 NE MIAMI CT, SUITE 2-15
MIAMI, FL 33132
PH: (954) 399-8478
FAX: (954) 744-4738
WEB: www.buildingdrops.com



REMARKS	BY	DATE

THE INSTALLATION DETAILS DESCRIBED HEREIN ARE GENERIC AND MAY NOT REFLECT ACTUAL CONDITIONS FOR A SPECIFIC SITE. IF SITE CONDITIONS CAUSE INSTALLATION TO DEVIATE FROM THE REQUIREMENTS DETAILED HEREIN, A LICENSED ENGINEER OR ARCHITECT SHALL PREPARE SITE SPECIFIC DOCUMENTS FOR USE WITH THIS DOCUMENT.

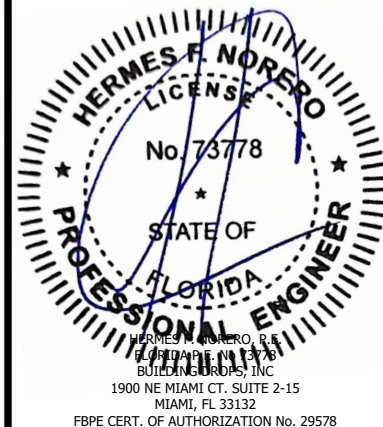

FL #: **FL47925**

DATE: **12.01.2025**

DWG. BY: **JR** CHK. BY: **HFN**

SCALE: **NTS**

DWG. #: **ODL012**

SHEET:

7

OF 25

c:\users\julianarodriguez\building_drops, inc\building_drops_projects\odl, inc\bc-25-0439_1 - submittal - odl fiberglass doors component additions\dwg\glazed\odl012.dwg 12/10/2025 4:41 PM



215 EAST ROOSEVELT AVE.
ZEELAND, MICHIGAN 49464

PH: (800) 253-3900

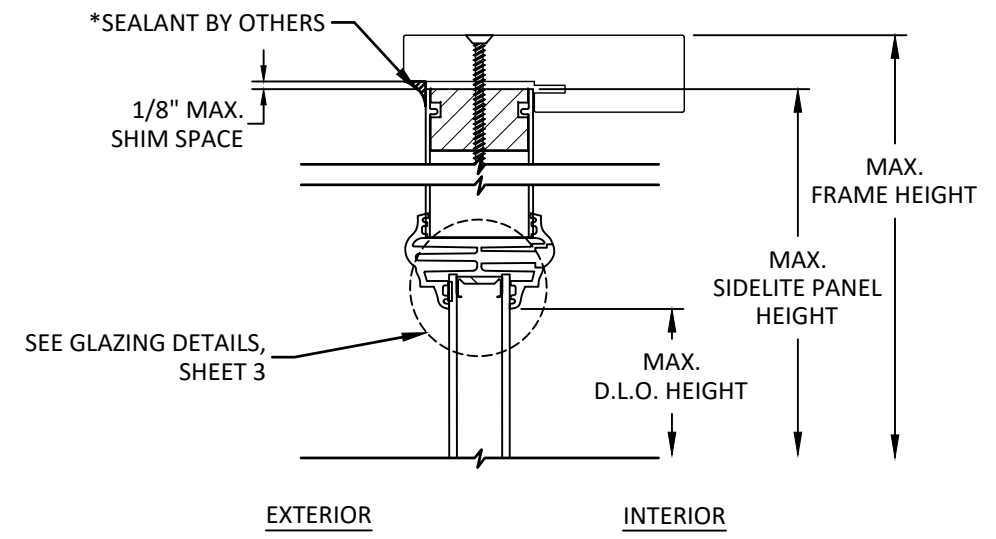

A
13 VERTICAL SECTION
OUTSWING - SIDELITE HEAD
EVOLVE FRAME

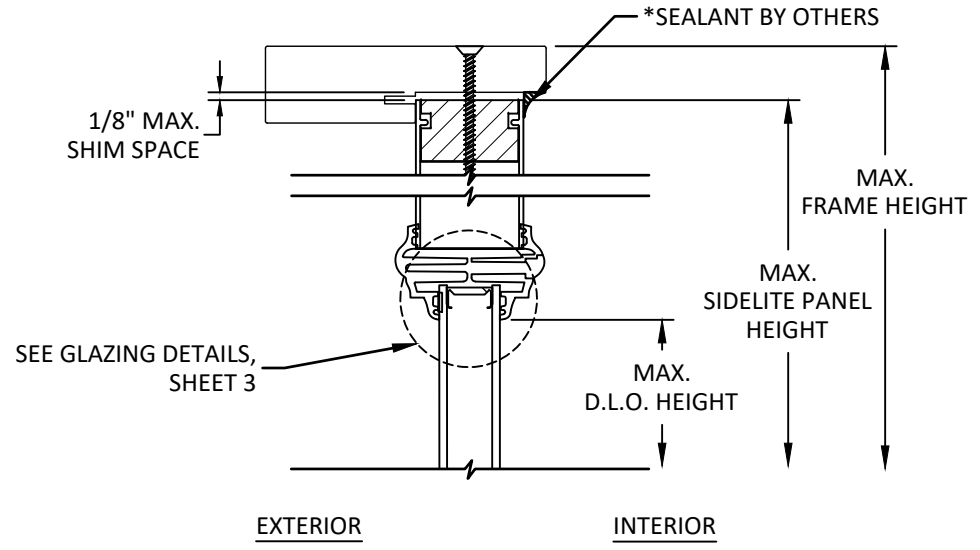

C
13 VERTICAL SECTION
INSWING - SIDELITE HEAD
EVOLVE FRAME

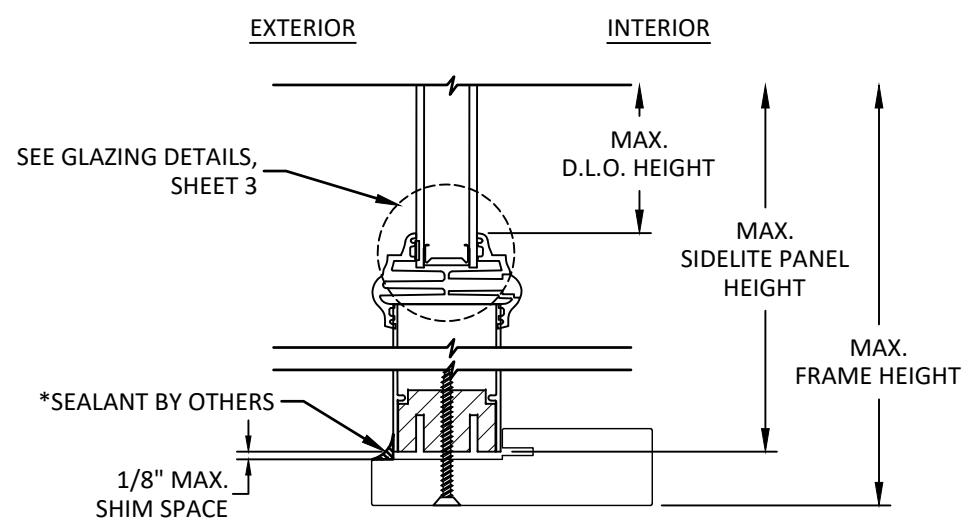

B
13 VERTICAL SECTION
OUTSWING - SIDELITE SILL
EVOLVE FRAME

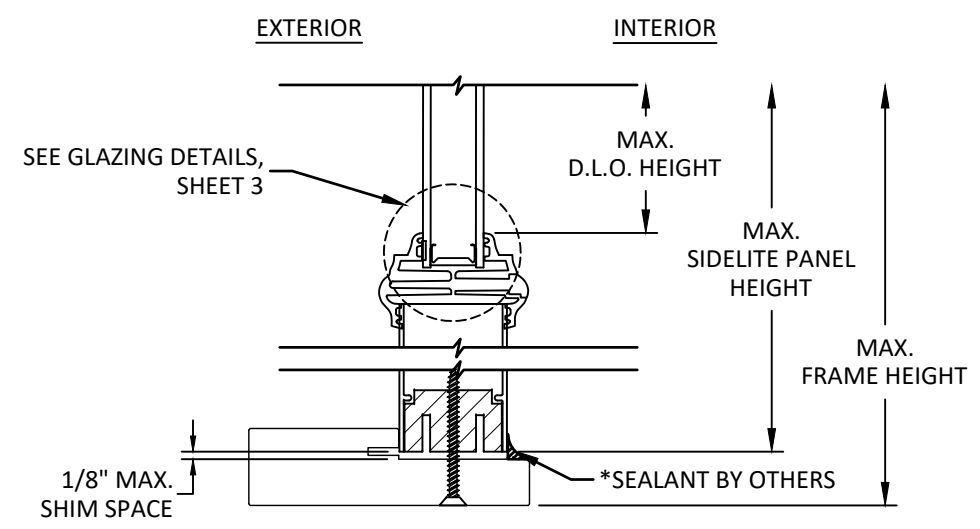

D
13 VERTICAL SECTION
INSWING - SIDELITE SILL
EVOLVE FRAME

TITLE:
INSWING & OUTSWING GLAZED
FIBERGLASS DOOR (NON-HVHZ)
(NON-IMPACT)

VERTICAL SECTIONS

PREPARED BY:
BUILDING DROPS, INC.
1900 NE MIAMI CT. SUITE 2-15
MIAMI, FL 33132
PH: (954) 399-8478
FAX: (954) 744-4738
WEB: www.buildingdrops.com



REMARKS	BY	DATE

THE INSTALLATION DETAILS DESCRIBED HEREIN ARE GENERIC AND MAY NOT REFLECT ACTUAL CONDITIONS FOR A SPECIFIC SITE. IF SITE CONDITIONS CAUSE INSTALLATION TO DEVIATE FROM THE REQUIREMENTS DETAILED HEREIN, A LICENSED ENGINEER OR ARCHITECT SHALL PREPARE SITE SPECIFIC DOCUMENTS FOR USE WITH THIS DOCUMENT.

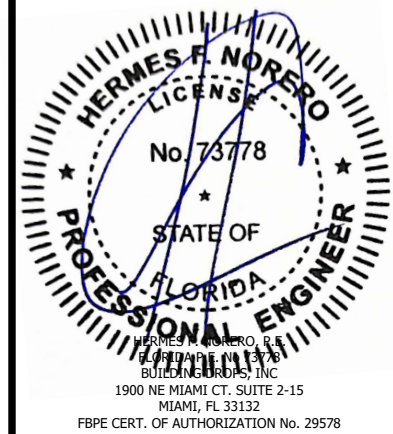

FL #: **FL47925**

DATE: **12.01.2025**

DWG. BY: **JR** CHK. BY: **HFN**

SCALE: **NTS**

DWG. #: **ODL012**

SHEET:
13
OF 25

c:\Users\julianarodriguez\building_drops, inc\building_drops_projects\odl, inc\bc-25-0439_1 - submittal - odl fiberglass doors component additions\dwg\glazed\odl012.dwg 12/10/2025 4:41 PM

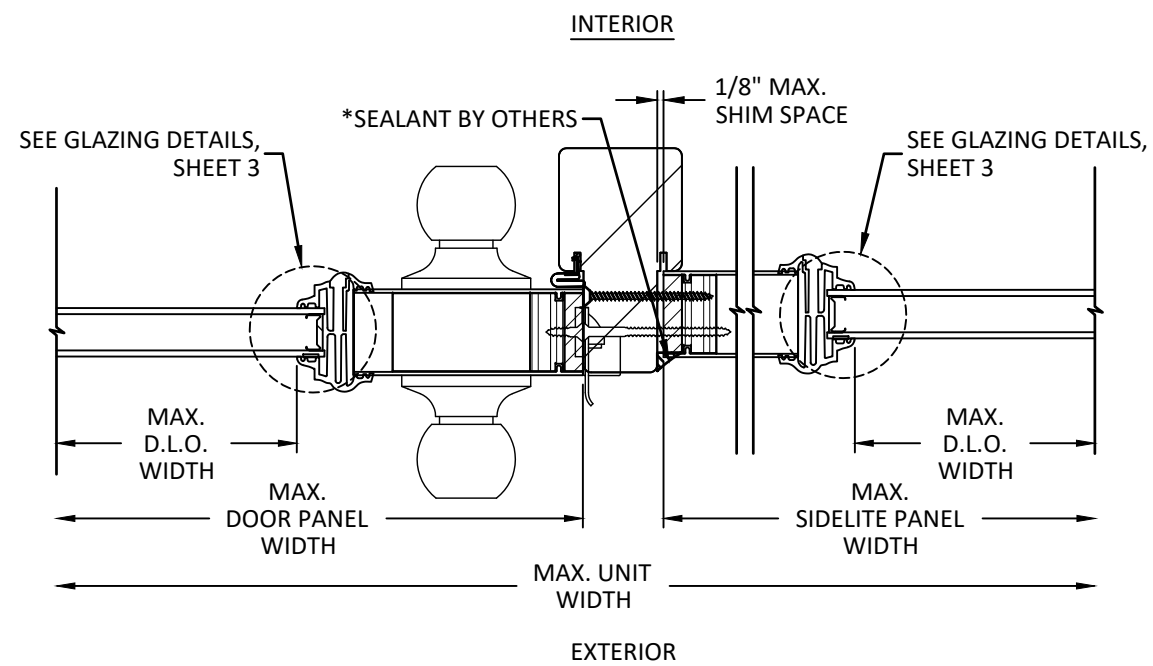

A HORIZONTAL SECTION
17

OUTSWING - ENDURA FRAME
SAVER MULLION
EVOLVE FRAME
CONTINUOUS CONSTRUCTION
RATED TO A MAX. DP OF +/- 32.7 PSF

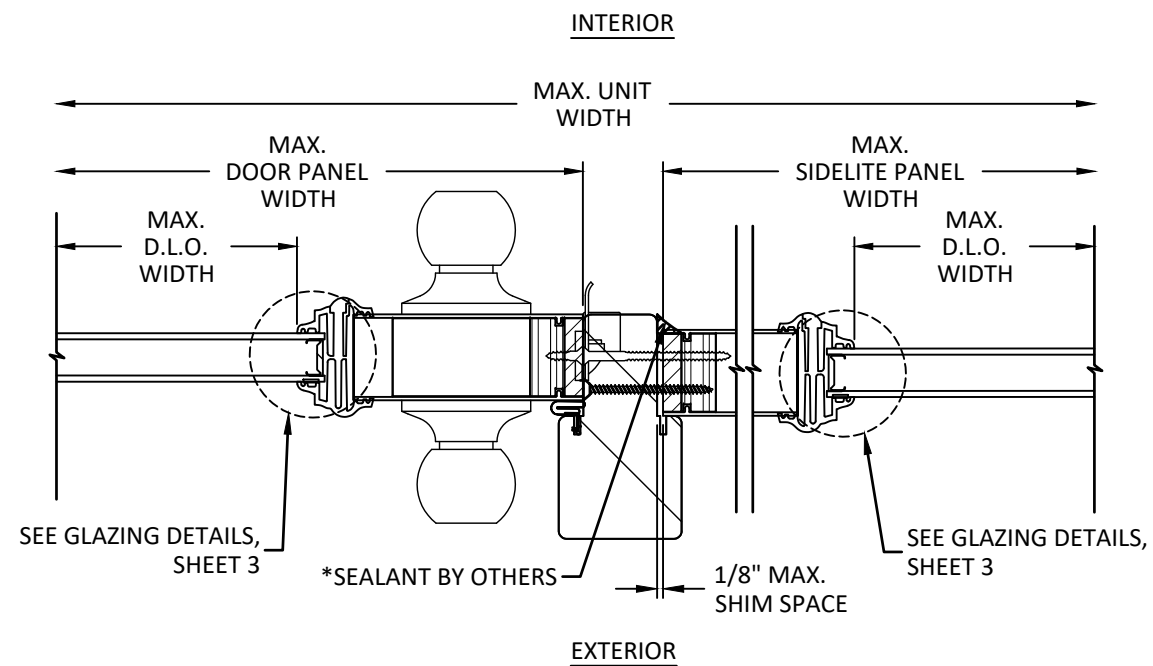

B HORIZONTAL SECTION
17

INSWING - ENDURA FRAME
SAVER MULLION
EVOLVE FRAME
RATED TO A MAX. DP OF +/- 32.7 PSF
CONTINUOUS CONSTRUCTION

NOTE: BOX AND CONTINUOUS CONSTRUCTION QUALIFIED FOR USE WITH EVOLVE FRAME.



215 EAST ROOSEVELT AVE.
ZEELAND, MICHIGAN 49464

PH: (800) 253-3900

TITLE: INSWING & OUTSWING GLAZED FIBERGLASS DOOR (NON-HVHZ) (NON-IMPACT)

HORIZONTAL SECTIONS

PREPARED BY: BUILDING DROPS, INC.
1900 NE MIAMI CT, SUITE 2-15
MIAMI, FL 33132
PH: (954) 399-8478
FAX: (954) 744-4738
WEB: www.buildingdrops.com



REMARKS	BY	DATE

THE INSTALLATION DETAILS DESCRIBED HEREIN ARE GENERIC AND MAY NOT REFLECT ACTUAL CONDITIONS FOR A SPECIFIC SITE. IF SITE CONDITIONS CAUSE INSTALLATION TO DEVIATE FROM THE REQUIREMENTS DETAILED HEREIN, A LICENSED ENGINEER OR ARCHITECT SHALL PREPARE SITE SPECIFIC DOCUMENTS FOR USE WITH THIS DOCUMENT.

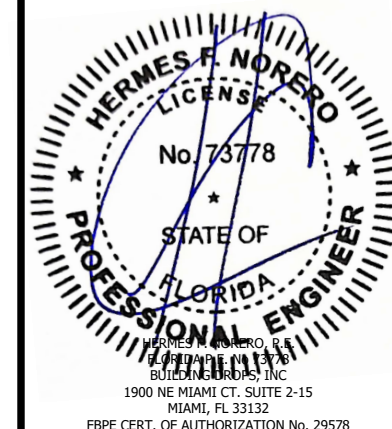

FL #: **FL47925**

DATE: **12.01.2025**

DWG. BY: **JR** CHK. BY: **HFN**

SCALE: **NTS**

DWG. #: **ODL012**

SHEET: **17**

OF 25

c:\users\julianarodriguez\building_drops, inc\building_drops\building_drops, inc\documents\common\projects\odl, inc\bc-25-0439_1 - submittal - odl fiberglass doors component additions\dwg\glazed\odl012.dwg 12/10/2025 4:41 PM

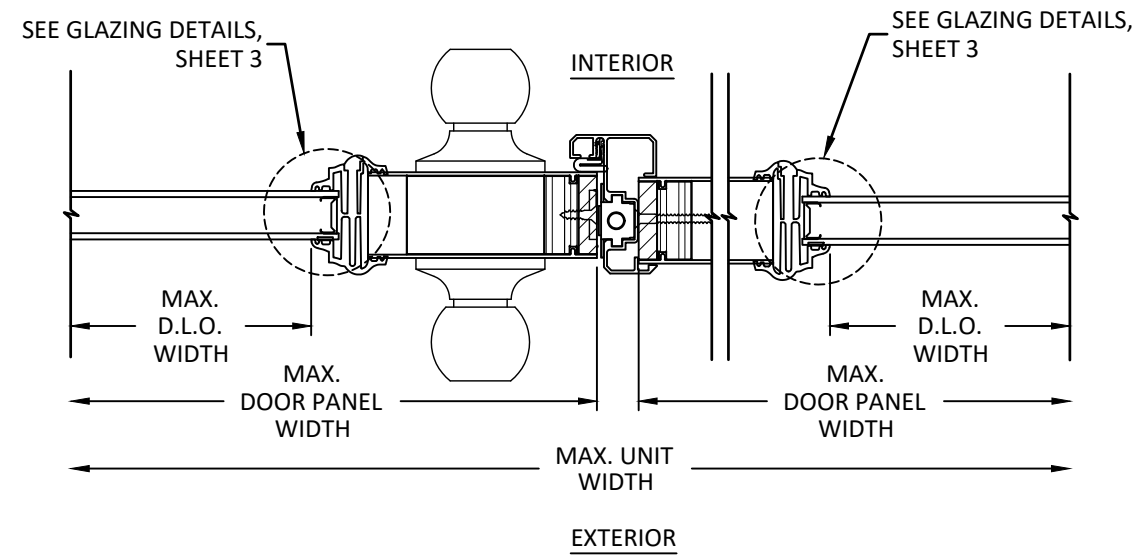

A HORIZONTAL SECTION
18 OUTSWING - DLP MODERN ASTRAGAL EVOLVE FRAME

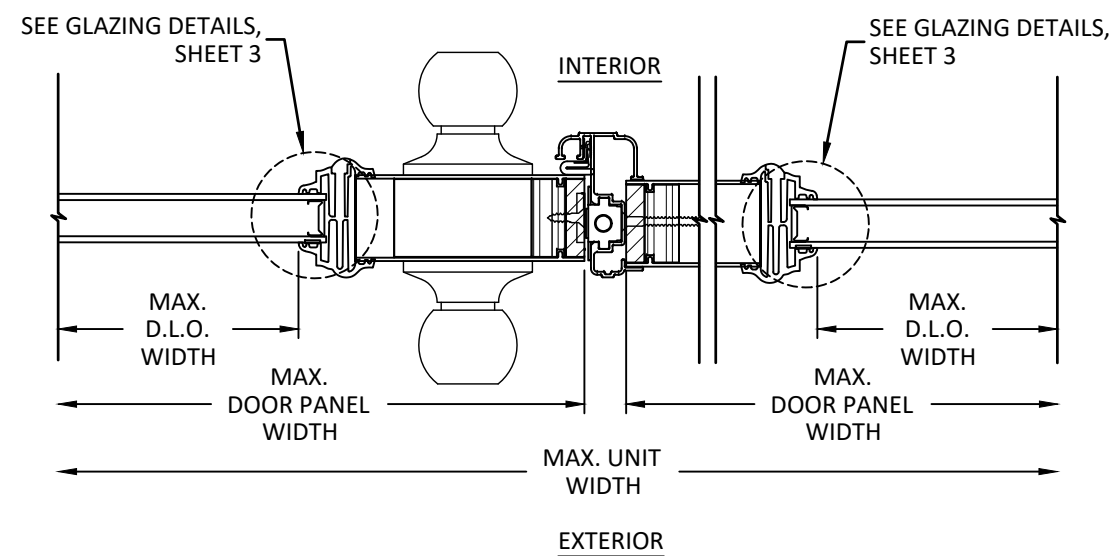

C HORIZONTAL SECTION
18 OUTSWING - DLP TRADITIONAL ASTRAGAL EVOLVE FRAME

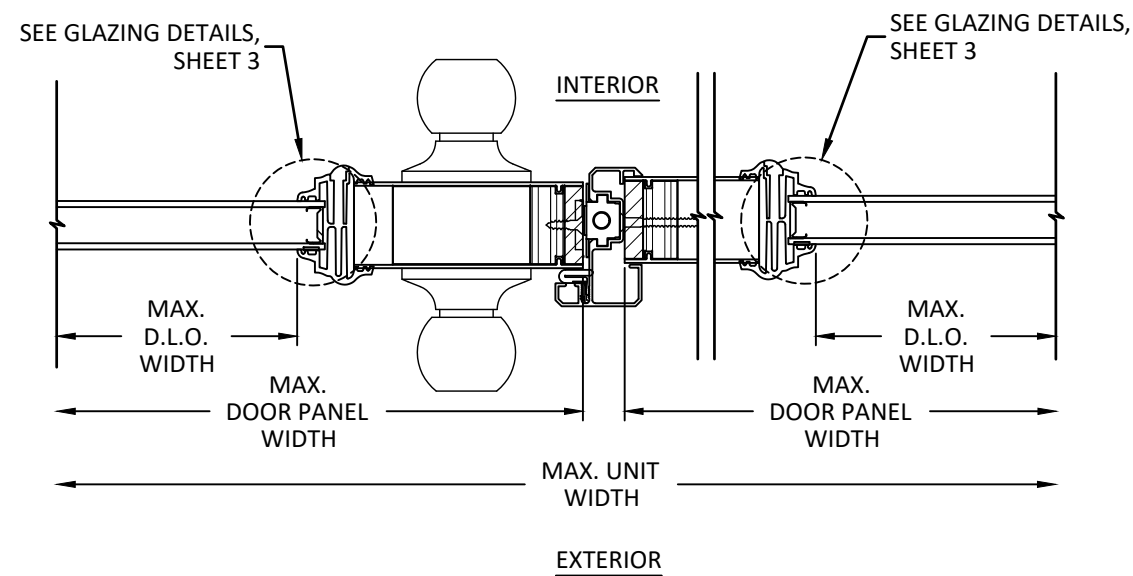

B HORIZONTAL SECTION
18 INSWING - DLP MODERN ASTRAGAL EVOLVE FRAME

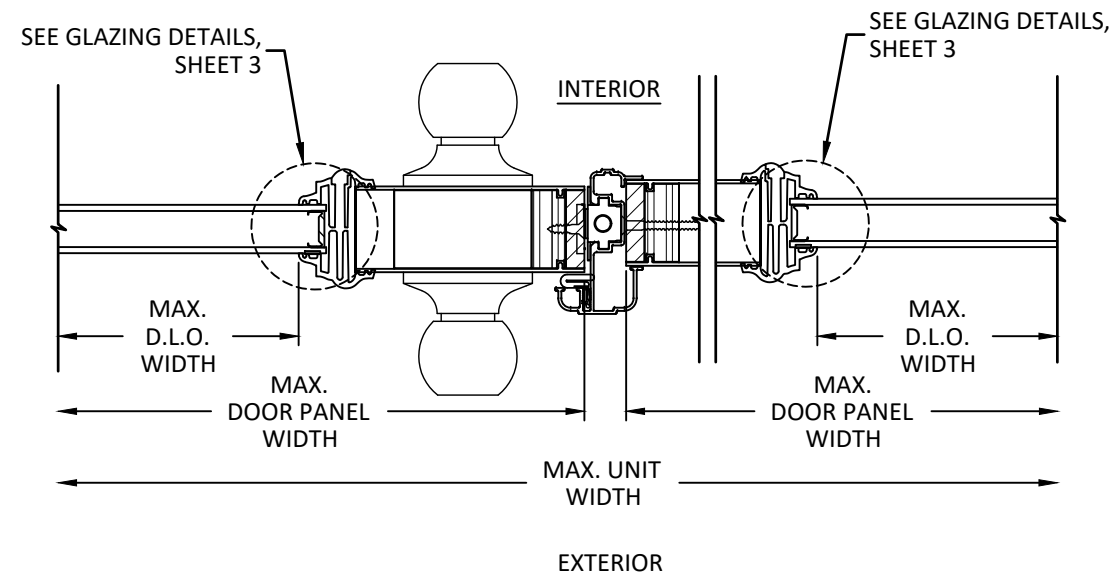

D HORIZONTAL SECTION
18 INSWING - DLP TRADITIONAL ASTRAGAL EVOLVE FRAME

NOTE: ALL ASTRAGALS QUALIFIED FOR USE WITH EVOLVE FRAME.



215 EAST ROOSEVELT AVE.
 ZEELAND, MICHIGAN 49464

PH: (800) 253-3900

TITLE: INSWING & OUTSWING GLAZED FIBERGLASS DOOR (NON-HVHZ) (NON-IMPACT)

HORIZONTAL SECTIONS

PREPARED BY: BUILDING DROPS, INC.

1900 NE MIAMI CT. SUITE 2-15
 MIAMI, FL 33132
 PH: (954) 399-8478
 FAX: (954) 744-4738
 WEB: www.buildingdrops.com



REMARKS	BY	DATE

THE INSTALLATION DETAILS DESCRIBED HEREIN ARE GENERIC AND MAY NOT REFLECT ACTUAL CONDITIONS FOR A SPECIFIC SITE. IF SITE CONDITIONS CAUSE INSTALLATION TO DEVIATE FROM THE REQUIREMENTS DETAILED HEREIN, A LICENSED ENGINEER OR ARCHITECT SHALL PREPARE SITE SPECIFIC DOCUMENTS FOR USE WITH THIS DOCUMENT.

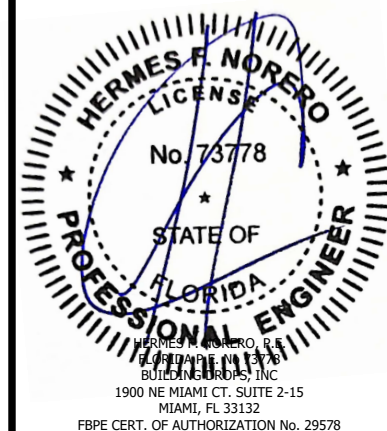

FL #: **FL47925**

DATE: **12.01.2025**

DWG. BY: **JR** CHK. BY: **HFN**

SCALE: **NTS**

DWG. #: **ODL012**

SHEET: **18**

OF 25

12/10/2025 4:41 PM
 c:\users\julianarodriguez\building_drops, inc\building_drops, inc\documents\common\projects\odi, inc\bc-25-0439_1 - submittal - odi fiberglass doors component additions\dwg\glazed\odi012.dwg

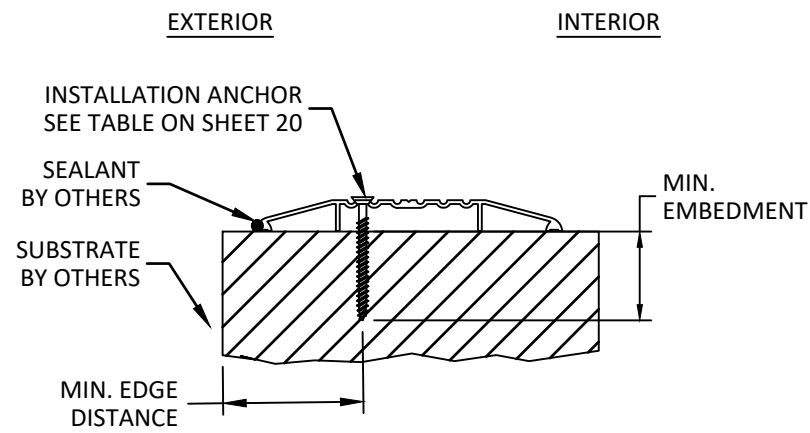

A
20
ANCHOR DETAIL
DLP ADA ISHC SILL

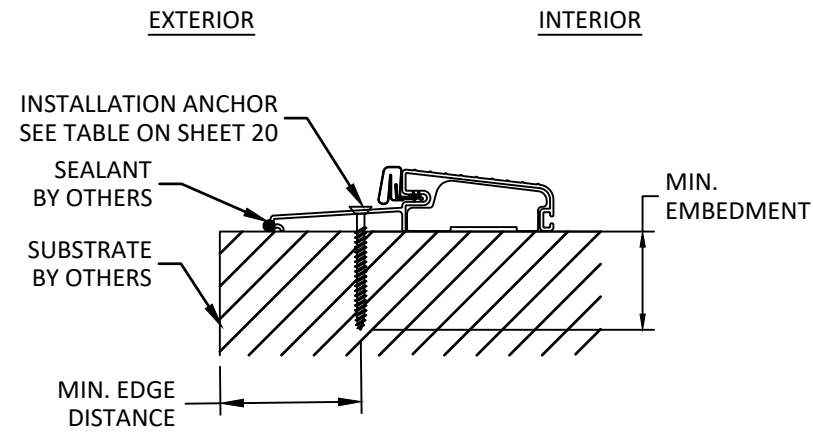

B
20
ANCHOR DETAIL
ENDURA FOB4565 SILL

INSTALLATION NOTES:

- ONE (1) INSTALLATION ANCHOR IS REQUIRED AT EACH ANCHOR LOCATION SHOWN FOR THROUGH FRAME INSTALLATION.
- THE NUMBER OF INSTALLATION ANCHORS DEPICTED IS THE MINIMUM NUMBER OF ANCHORS TO BE USED FOR PRODUCT INSTALLATION OF THE MAXIMUM SIZE LISTED.
- INSTALL INDIVIDUAL INSTALLATION ANCHORS WITHIN A TOLERANCE OF $\pm 1/4$ INCH THE DEPICTED LOCATION & SPACING IN THE ANCHOR LAYOUT DETAILS (I.E., WITHOUT CONSIDERATION OF TOLERANCES). TOLERANCES ARE NOT CUMULATIVE FROM ONE INSTALLATION ANCHOR TO THE NEXT.
- SHIM AS REQUIRED AT EACH INSTALLATION ANCHOR WITH LOAD BEARING SHIM(S). MAXIMUM ALLOWABLE SHIM STACK TO BE 1/4 INCH. SHIM WHERE SPACE OF 1/16 INCH OR GREATER OCCURS. SHIM(S) SHALL BE CONSTRUCTED OF HIGH DENSITY PLASTIC OR BETTER.
- FOR MASONRY OR CONCRETE OPENINGS, A 1X WOOD BUCK MAY BE USED (OPTIONAL) AS LONG AS THE MINIMUM EMBEDMENT AND EDGE DISTANCE REQUIREMENTS ARE STILL MET WITHIN THE CORRESPONDING HOST SUBSTRATE. SEE GENERAL NOTE #3 ON SHEET 1 FOR MORE INFORMATION.
- MINIMUM EMBEDMENT AND EDGE DISTANCE EXCLUDE WALL FINISHES, INCLUDING BUT NOT LIMITED TO STUCCO, FOAM, BRICK VENEER, AND SIDING.
- INSTALLATION ANCHORS AND ASSOCIATED HARDWARE MUST BE MADE OF CORROSION RESISTANT MATERIAL OR HAVE A CORROSION RESISTANT COATING.
- FOR HOLLOW BLOCK AND GROUT FILLED BLOCK, DO NOT INSTALL INSTALLATION ANCHORS INTO MORTAR JOINTS. EDGE DISTANCE IS MEASURED FROM FREE EDGE OF BLOCK OR EDGE OF MORTAR JOINT INTO FACE SHELL OF BLOCK.
- INSTALLATION ANCHORS SHALL BE INSTALLED IN ACCORDANCE WITH ANCHOR MANUFACTURER'S INSTALLATION INSTRUCTIONS, AND ANCHORS SHALL NOT BE USED IN SUBSTRATES WITH STRENGTHS LESS THAN THE MINIMUM STRENGTH SPECIFIED BY THE ANCHOR MANUFACTURER.

ANCHOR SCHEDULE				
METHOD	SUBSTRATE	ANCHOR TYPE	MIN. EMBEDMENT	MIN. EDGE DISTANCE
THROUGH FRAME	WOOD: MIN. S.G. = 0.55	#10 WOOD SCREW	1.50"	0.75"
	CONCRETE (MIN. f'c = 3000 PSI) OR CMU (PER ASTM C90)	3/16" ITW TAPCON	1.00"	2.50"
	STEEL MIN. 18 GA. (MIN. Fy = 36 KSI) ALUM. MIN. 1/8" THK. (MIN. 6063-T5)	#12 SELF-TAPPING OR SELF-DRILLING SCREW	3 THREADS MIN PENETRATION BEYOND METAL	0.50"



215 EAST ROOSEVELT AVE.
ZEELAND, MICHIGAN 49464

PH: (800) 253-3900

TITLE:
 INSWING & OUTSWING GLAZED
 FIBERGLASS DOOR (NON-HVHZ)
 (NON-IMPACT)

**ANCHOR DETAILS, ANCHOR SCHEDULE,
 & INSTALLATION NOTES**

PREPARED BY:
 BUILDING DROPS, INC.
 1900 NE MIAMI CT., SUITE 2-15
 MIAMI, FL 33132
 PH: (954) 399-8478
 FAX: (954) 744-4738
 WEB: www.buildingdrops.com



REMARKS	BY	DATE

THE INSTALLATION DETAILS DESCRIBED HEREIN ARE GENERIC AND MAY NOT REFLECT ACTUAL CONDITIONS FOR A SPECIFIC SITE. IF SITE CONDITIONS CAUSE INSTALLATION TO DEVIATE FROM THE REQUIREMENTS DETAILED HEREIN, A LICENSED ENGINEER OR ARCHITECT SHALL PREPARE SITE SPECIFIC DOCUMENTS FOR USE WITH THIS DOCUMENT.

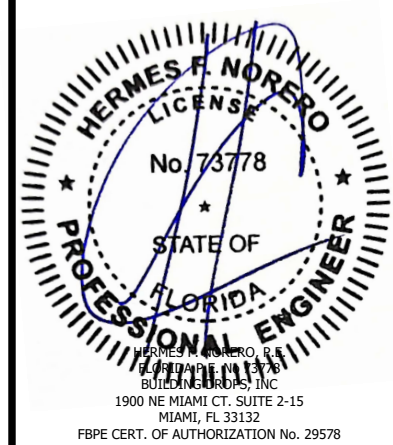

FL #:

FL47925

DATE: 12.01.2025

DWG. BY: JR	CHK. BY: HFN
----------------	-----------------

SCALE: NTS

DWG. #: ODL012

SHEET:

20

OF 25

c:\users\julianarodriguez\building_drops, inc\building_drops_projects\odl, inc\bc-25-0439, 1 - submittal - odl fiberglass doors component additions\dwgs\glazed\odl012.dwg
 12/10/2025 4:41 PM



215 EAST ROOSEVELT AVE.
ZEELAND, MICHIGAN 49464

PH: (800) 253-3900

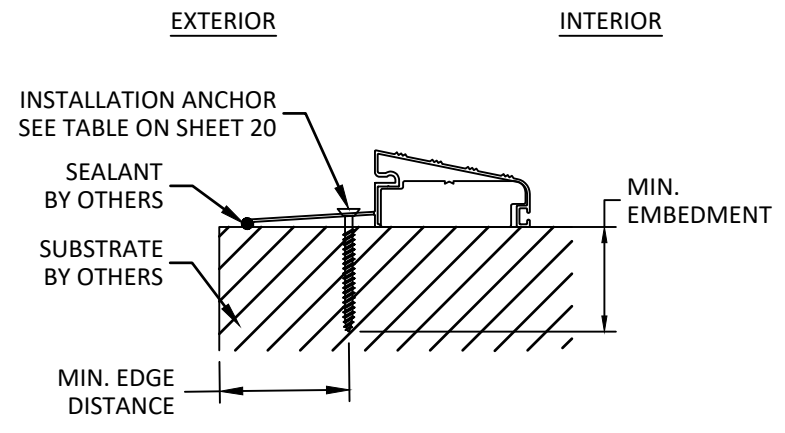

A
21 ANCHOR DETAIL
QOSH SILL

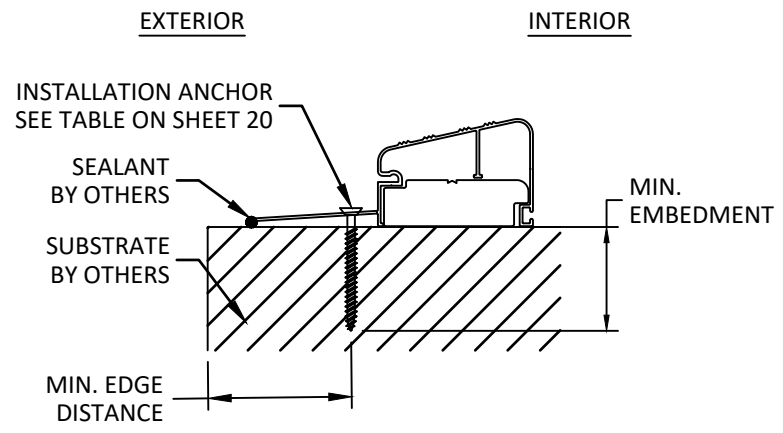

B
21 ANCHOR DETAIL
QOSR SILL

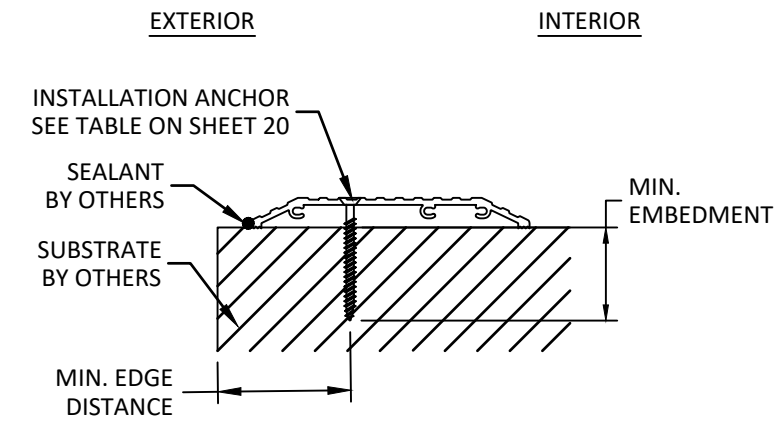

C
21 ANCHOR DETAIL
DLP ADA DB4565DL SILL

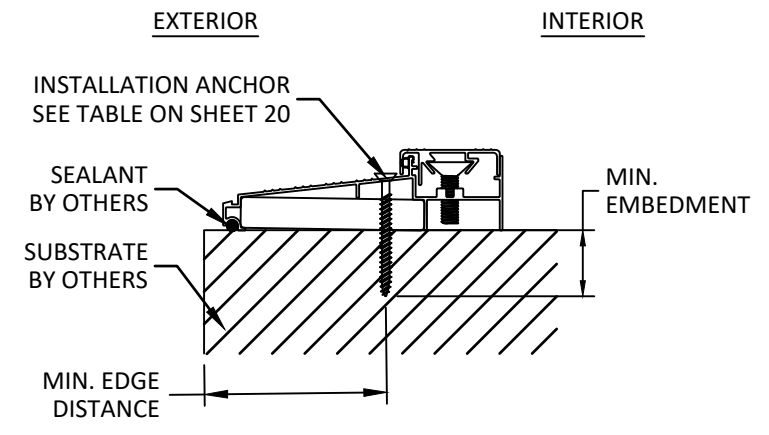

D
21 ANCHOR DETAIL
DLP ISCS SILL

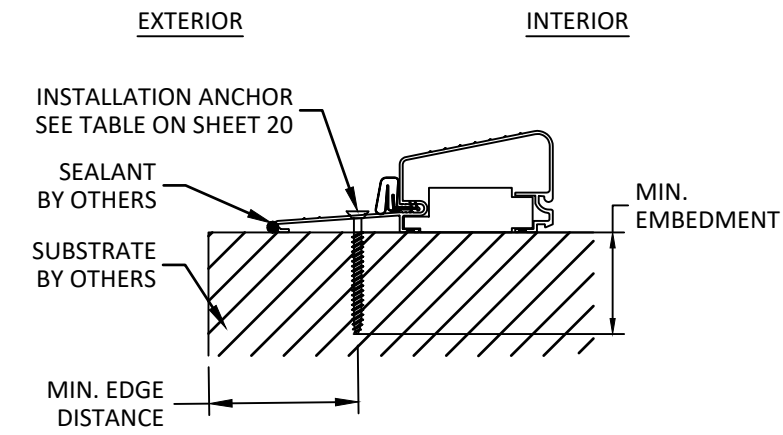

E
21 ANCHOR DETAIL
AFCO H-497 SILL

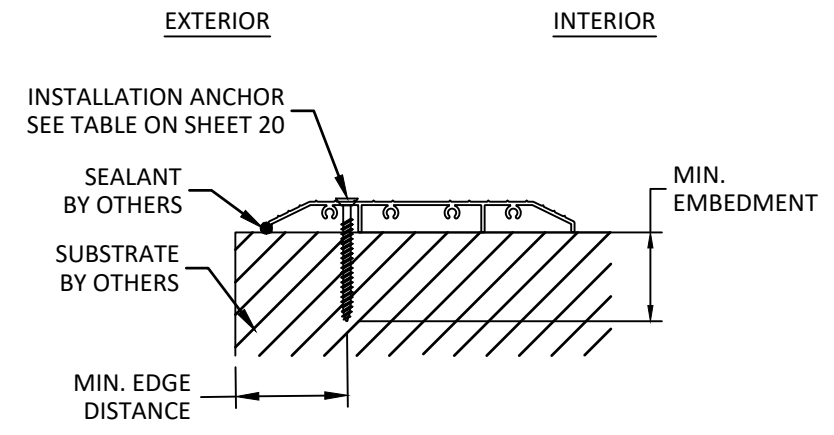

F
21 ANCHOR DETAIL
ENDURA HC15000 ADA SILL

TITLE:
INSWING & OUTSWING GLAZED
FIBERGLASS DOOR (NON-HVHZ)
(NON-IMPACT)

ANCHOR DETAILS

PREPARED BY:
BUILDING DROPS, INC.
1900 NE MIAMI CT, SUITE 2-15
MIAMI, FL 33132
PH: (954) 399-8478
FAX: (954) 744-4738
WEB: www.buildingdrops.com



REMARKS	BY	DATE

THE INSTALLATION DETAILS DESCRIBED HEREIN ARE GENERIC AND MAY NOT REFLECT ACTUAL CONDITIONS FOR A SPECIFIC SITE. IF SITE CONDITIONS CAUSE INSTALLATION TO DEVIATE FROM THE REQUIREMENTS DETAILED HEREIN, A LICENSED ENGINEER OR ARCHITECT SHALL PREPARE SITE SPECIFIC DOCUMENTS FOR USE WITH THIS DOCUMENT.

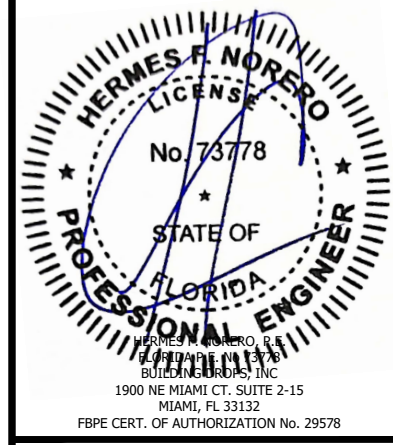

FL #: **FL47925**

DATE: **12.01.2025**

DWG. BY: **JR** CHK. BY: **HFN**

SCALE: **NTS**

DWG. #: **ODL012**

SHEET:
21
OF 25

c:\users\julianarodriguez\building_drops, inc\building_drops_projects\odl, inc\bc-25-0439_1 - submittal - odl fiberglass doors component additions\dwg\glazed\odl012.dwg 12/10/2025 4:41 PM



215 EAST ROOSEVELT AVE.
ZEELAND, MICHIGAN 49464

PH: (800) 253-3900

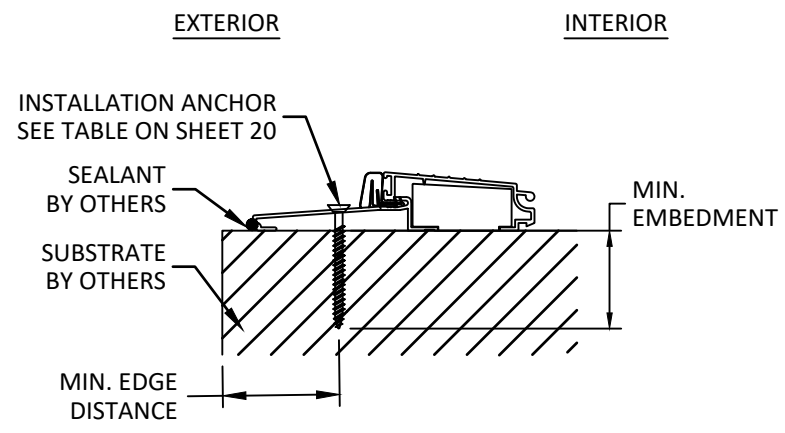

A
22 ANCHOR DETAIL
AFCO A-117 SILL

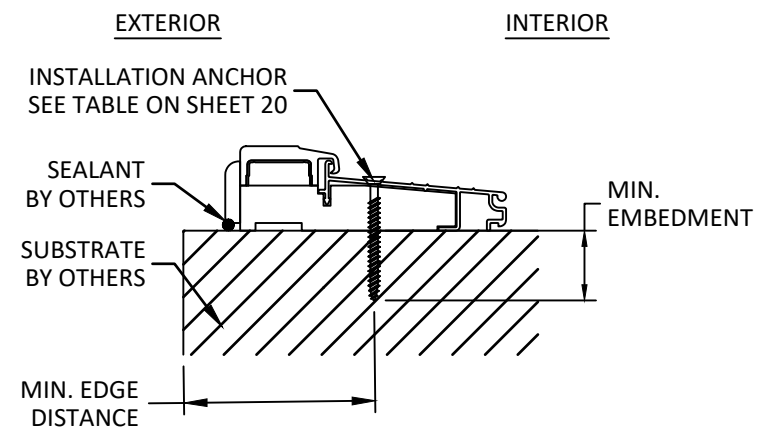

B
22 ANCHOR DETAIL
AFCO A-276 SILL

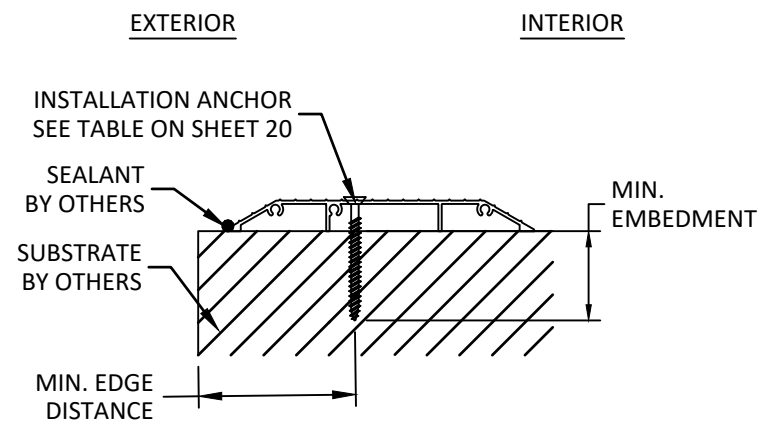

C
22 ANCHOR DETAIL
AFCO A-204 SILL

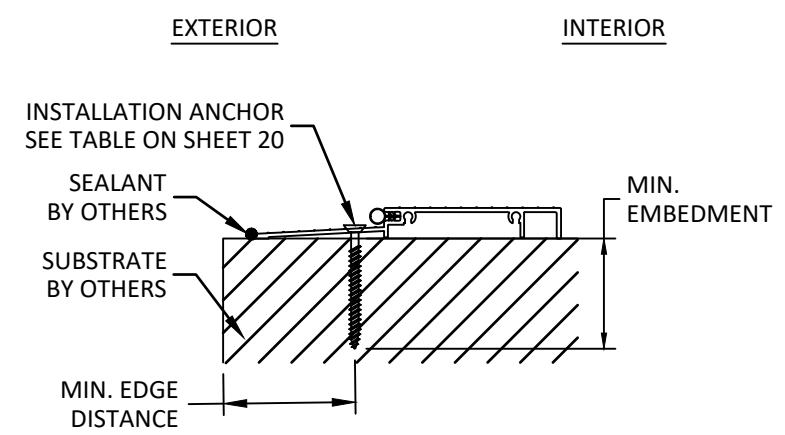

D
22 ANCHOR DETAIL
AFCO A-204T SILL

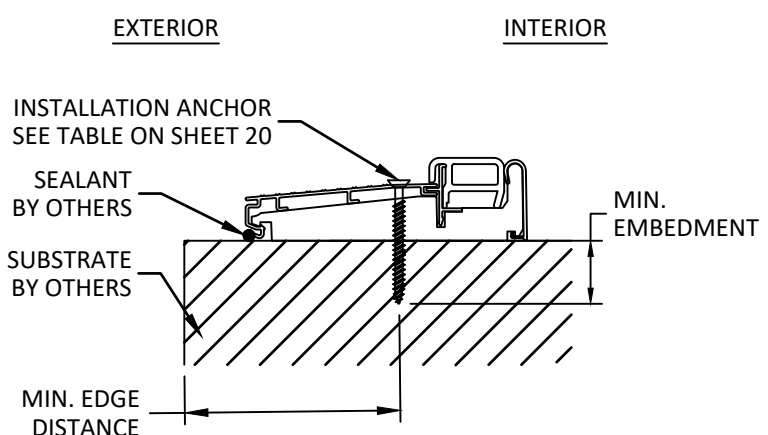

E
22 ANCHOR DETAIL
ENDURA ZAILAA4565 SILL

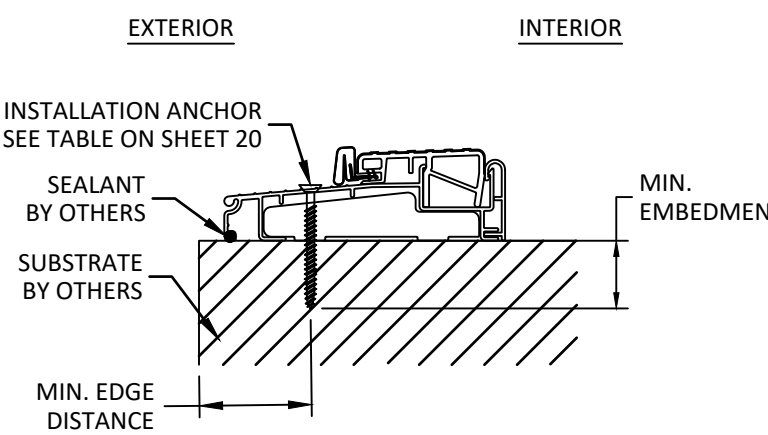

F
22 ANCHOR DETAIL
ENDURA ZOBL4565 SILL

TITLE: INSWING & OUTSWING GLAZED FIBERGLASS DOOR (NON-HVHZ) (NON-IMPACT) ANCHOR DETAILS

PREPARED BY: BUILDING DROPS, INC.
1900 NE MIAMI CT., SUITE 2-15
MIAMI, FL 33132
PH: (954) 399-8478
FAX: (954) 744-4738
WEB: www.buildingdrops.com

REMARKS	BY	DATE

THE INSTALLATION DETAILS DESCRIBED HEREIN ARE GENERIC AND MAY NOT REFLECT ACTUAL CONDITIONS FOR A SPECIFIC SITE. IF SITE CONDITIONS CAUSE INSTALLATION TO DEVIATE FROM THE REQUIREMENTS DETAILED HEREIN, A LICENSED ENGINEER OR ARCHITECT SHALL PREPARE SITE SPECIFIC DOCUMENTS FOR USE WITH THIS DOCUMENT.

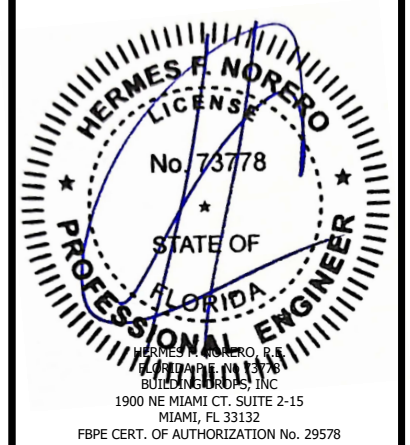

FL #: **FL47925**

DATE: **12.01.2025**

DWG. BY: **JR** CHK. BY: **HFN**

SCALE: **NTS**

DWG. #: **ODL012**

SHEET: **22**
OF 25

c:\users\julianarodriguez\building_drops, inc\building_drops_projects\odl, inc\bc-25-0439_1 - submittal - odl fiberglass doors component additions\dwg\glazed\odl012.dwg 12/10/2025 4:42 PM



215 EAST ROOSEVELT AVE.
ZEELAND, MICHIGAN 49464

PH: (800) 253-3900

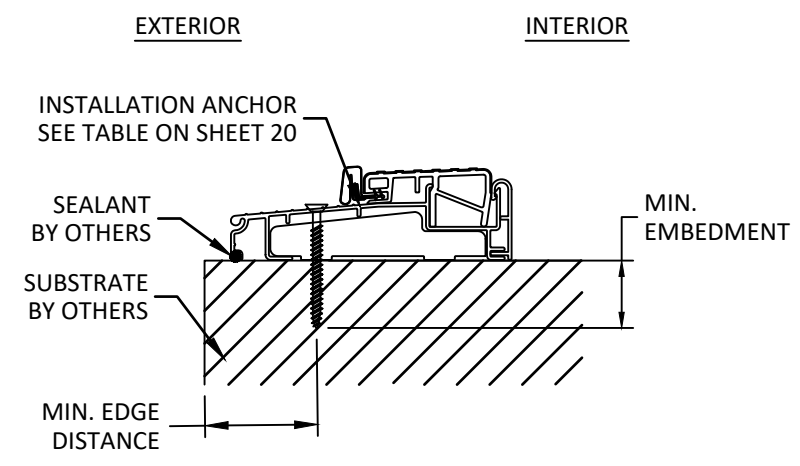

A
23 ANCHOR DETAIL
ENDURA ZOB4565FN SILL

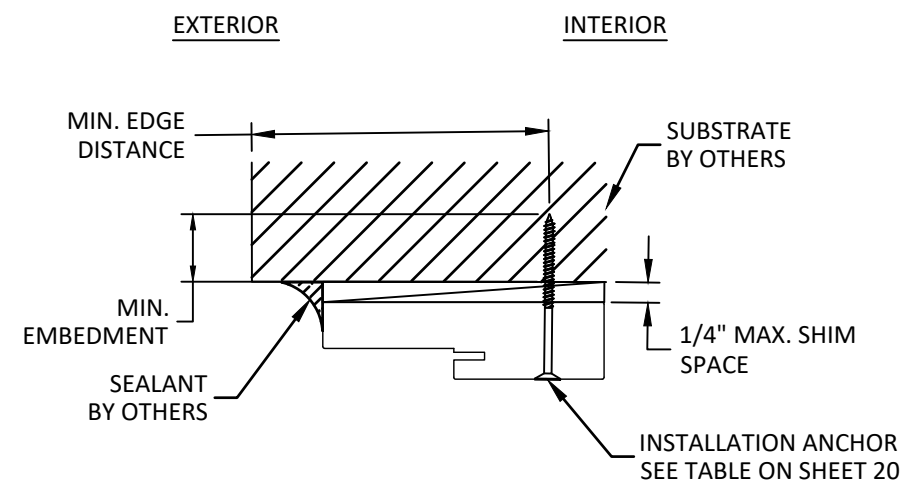

B
23 ANCHOR DETAIL
OUTSWING - DOOR HEAD
JAMB SIMILAR

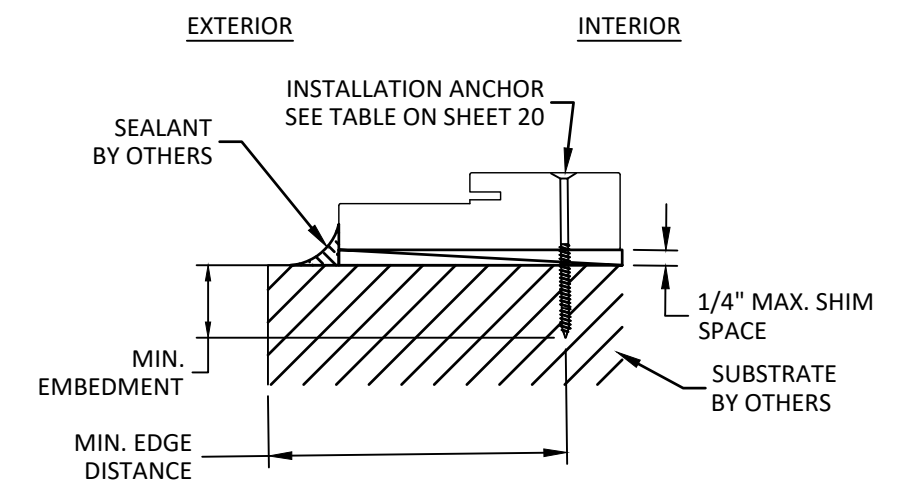

C
23 ANCHOR DETAIL
OUTSWING - SIDELITE SILL
HEAD AND JAMB SIMILAR

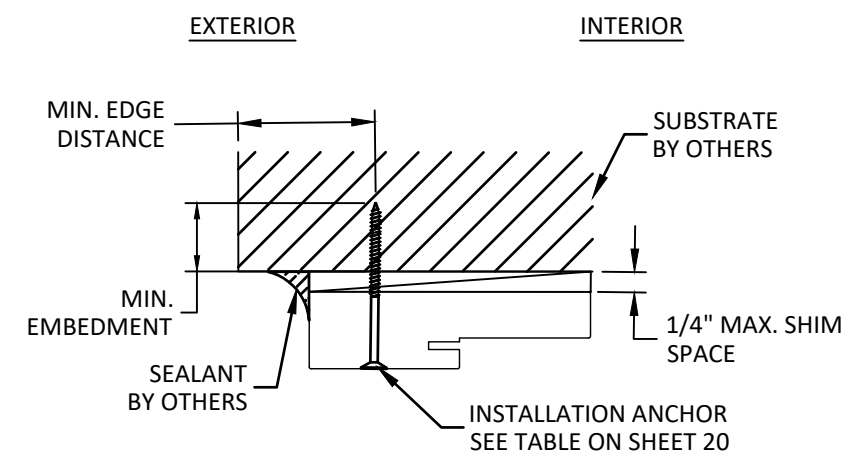

D
23 ANCHOR DETAIL
INSWING - DOOR HEAD
JAMB SIMILAR

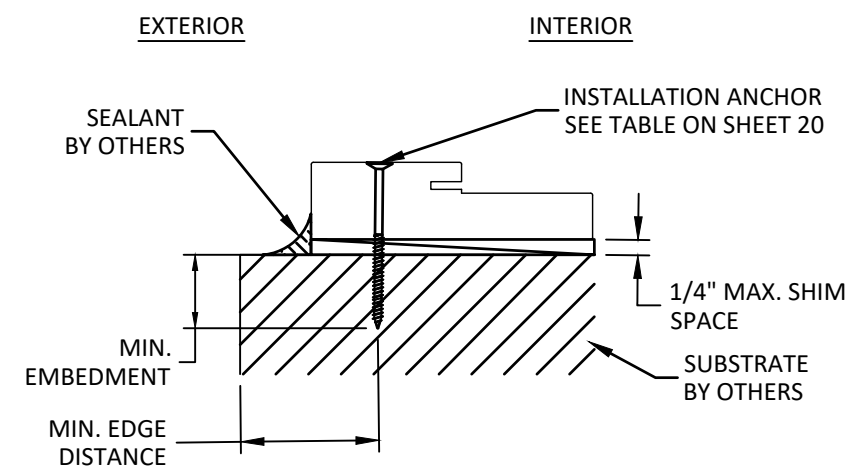

E
23 ANCHOR DETAIL
INSWING - SIDELITE SILL
HEAD AND JAMB SIMILAR

TITLE:
INSWING & OUTSWING GLAZED
FIBERGLASS DOOR (NON-HVHZ)
(NON-IMPACT)
ANCHOR DETAILS

PREPARED BY:
BUILDING DROPS, INC.
1900 NE MIAMI CT, SUITE 2-15
MIAMI, FL 33132
PH: (954) 399-8478
FAX: (954) 744-4738
WEB: www.buildingdrops.com

REMARKS	BY	DATE

THE INSTALLATION DETAILS DESCRIBED HEREIN ARE GENERIC AND MAY NOT REFLECT ACTUAL CONDITIONS FOR A SPECIFIC SITE. IF SITE CONDITIONS CAUSE INSTALLATION TO DEVIATE FROM THE REQUIREMENTS DETAILED HEREIN, A LICENSED ENGINEER OR ARCHITECT SHALL PREPARE SITE SPECIFIC DOCUMENTS FOR USE WITH THIS DOCUMENT.

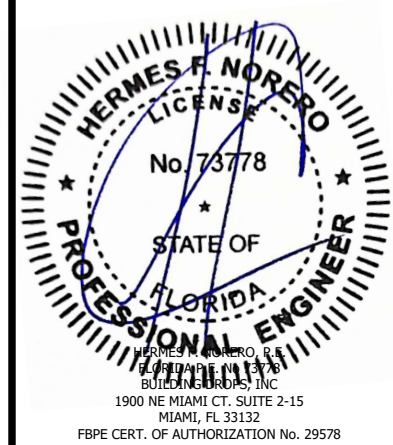

FL #:
FL47925

DATE: 12.01.2025

DWG. BY: JR
CHK. BY: HFN

SCALE: NTS

DWG. #: ODL012

SHEET:
23
OF 25

c:\users\julianarodriguez\building_drops, inc\building_drops_projects\odl, inc\bc-25-0439_1 - submittal - odl fiberglass doors component additions\dwg\glazed\odl012.dwg 12/10/2025 4:41 PM

BILL OF MATERIALS		
ITEM	DESCRIPTION	MATERIAL
1	JAMB	FINGER JOINT PINE, LVL, OR COMPOSITE
2	ENDURA FUSION MULLION	VARIES
3	BOXED MULLION	FINGER JOINT PINE OR LVL
4	WEATHERSTRIP	FOAM
5	DOOR SWEEP	VINYL
6	HINGE	STEEL
7	LOCK SET	STEEL
8	DEADBOLT	STEEL
9	LATCH STRIKE PLATE	STEEL
10	DEADBOLT STRIKE PLATE	STEEL
11	DOOR PANEL	-
12	SIDELITE PANEL	-
13	FASTENERS	STEEL
14	DLP MODERN ASTRAGAL	ALUMINUM
15	DLP TRADITIONAL ASTRAGAL	ALUMINUM
16	ASTRAGAL STRIKE PLATE	STEEL
17	DLP QOSH SILL	ALUMINUM
18	DLP QOSR SILL	ALUMINUM
19	AFCO H-497 SILL	ALUMINUM
20	DLP ISCS SILL	ALUMINUM
21	DLP ADA ISHC SILL	ALUMINUM
22	DLP DB4565DL SILL	ALUMINUM
23	ENDURA HC15000 ADA SILL	ALUMINUM
24	ENDURA FOB4565 SILL	ALUMINUM
25	ENDURA ZOB4565FN SILL	ALUMINUM
26	AFCO A-117 SILL	ALUMINUM
27	AFCO A-276 SILL	ALUMINUM
28	AFCO A-204 SILL	ALUMINUM
29	AFCO A-204T SILL	ALUMINUM
30	ENDURA ZAILAA4565 SILL	ALUMINUM
31	ENDURA ZOBL4565F SILL	ALUMINUM
32	AFCO SIDELITE BASE	PVC / ALUMINUM
33	ENDURA SIDELITE BASE	PVC / ALUMINUM
34	ENDURA ULTIMATE HURRICANE ASTRAGAL	ALUMINUM
35	ENDURA ULTIMATE PUSH BUTTON ASTRAGAL	ALUMINUM
36	PLASTPRO MULLION	VARIES
37	WOOD PINE MULLION	FINGER JOINT PINE
38	ENDURA FRAME SAVER MULLION	FINGER JOINT PINE

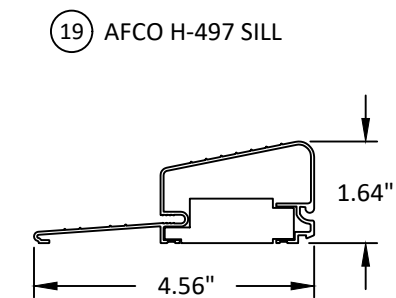
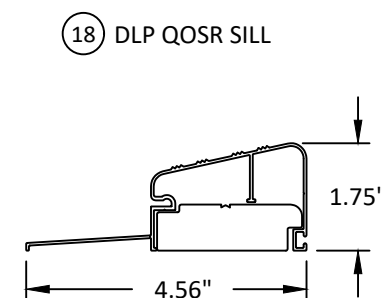
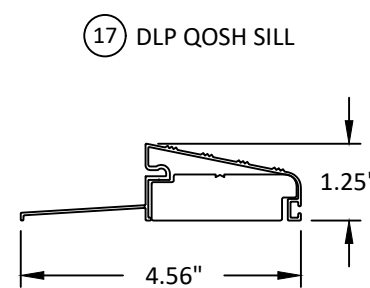
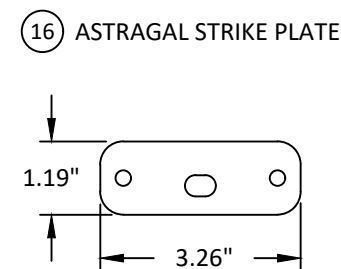
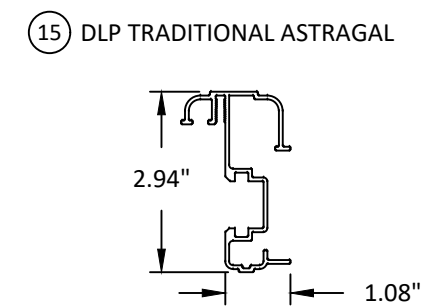
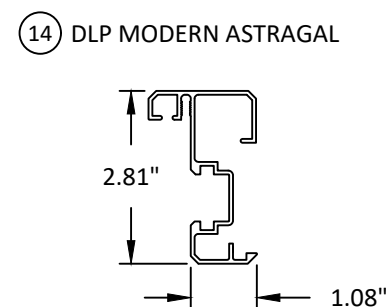
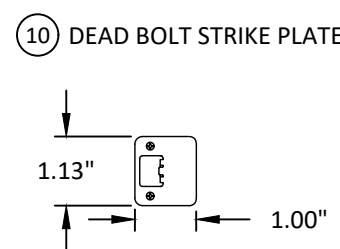
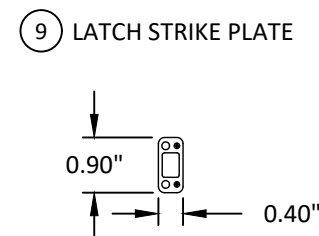
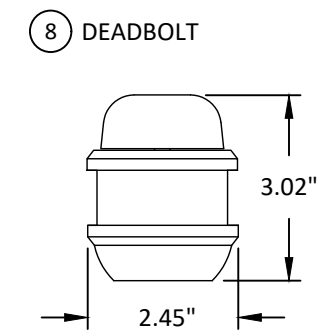
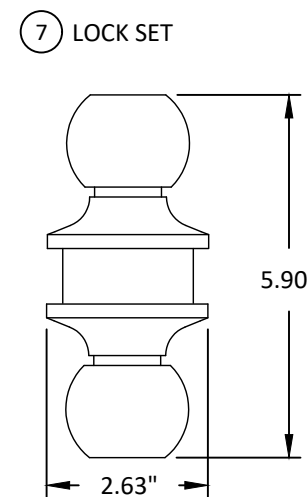
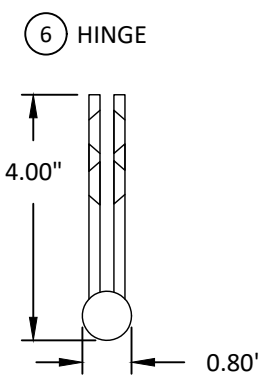
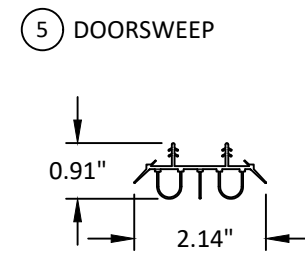
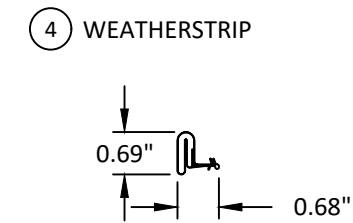
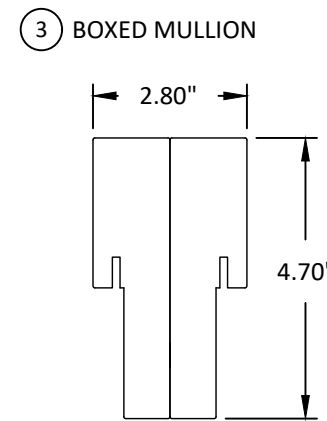
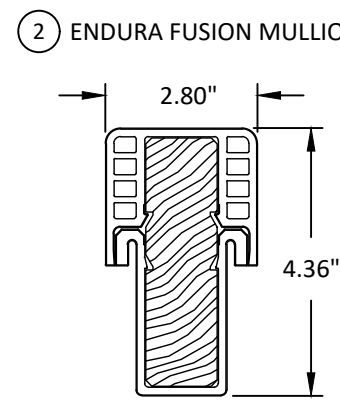
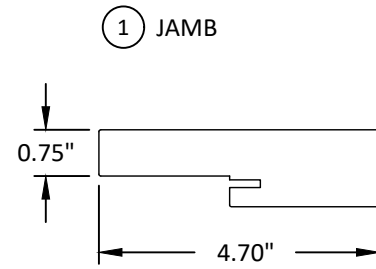

215 EAST ROOSEVELT AVE.
ZEELAND, MICHIGAN 49464

PH: (800) 253-3900

TITLE: INSWING & OUTSWING GLAZED FIBERGLASS DOOR (NON-HVHZ) (NON-IMPACT)
BILL OF MATERIALS & COMPONENTS

PREPARED BY: BUILDING DROPS, INC.
1900 NE MIAMI CT, SUITE 2-15
MIAMI, FL 33132
PH: (954) 399-8478
FAX: (954) 744-4738
WEB: www.buildingdrops.com



REMARKS	BY	DATE

THE INSTALLATION DETAILS DESCRIBED HEREIN ARE GENERIC AND MAY NOT REFLECT ACTUAL CONDITIONS FOR A SPECIFIC SITE. IF SITE CONDITIONS CAUSE INSTALLATION TO DEVIATE FROM THE REQUIREMENTS DETAILED HEREIN, A LICENSED ENGINEER OR ARCHITECT SHALL PREPARE SITE SPECIFIC DOCUMENTS FOR USE WITH THIS DOCUMENT.

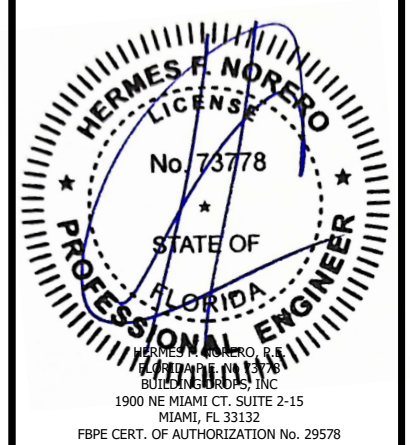

FL #:	FL47925
DATE:	12.01.2025
DWG. BY:	JR
CHK. BY:	HFN
SCALE:	NTS
DWG. #:	ODL012
SHEET:	24
	OF 25

c:\Users\julianarodriguez\building_drops, inc\building_drops_landing - documents\common\projects\odl, inc\bc-25-0439_1 - submittal - odl fiberglass doors component additions\dwg\glazed\odl012.dwg 12/10/2025 4:42 PM

20 DLP ISCS SILL

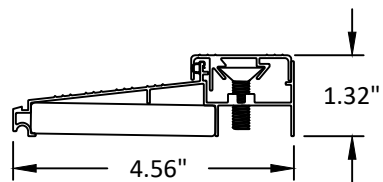

21 DLP ADA ISHC SILL

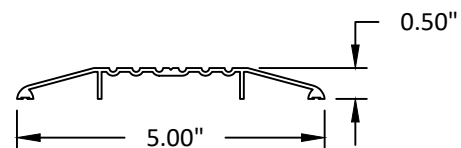

22 DLP DB4565DL SILL

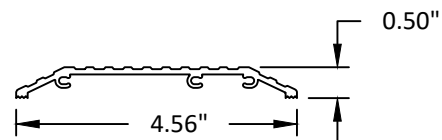

23 ENDURA HC15000 ADA SILL

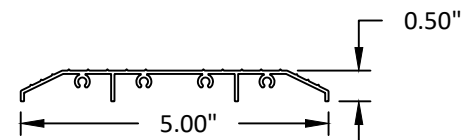

24 ENDURA FOB4565 SILL

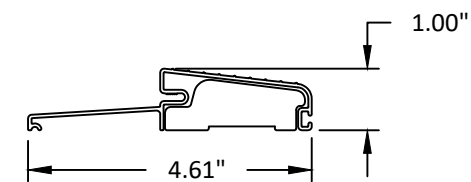

25 ENDURA ZOB4565FN SILL

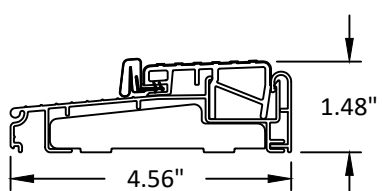

26 AFCO A-117 SILL

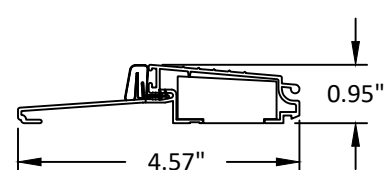

27 AFCO A-276 SILL

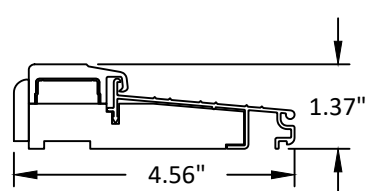

28 AFCO A-204 SILL

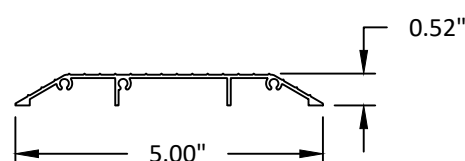

29 AFCO A-204T SILL

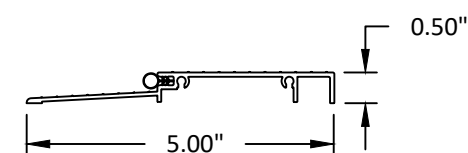

30 ENDURA ZAILAA4565 SILL

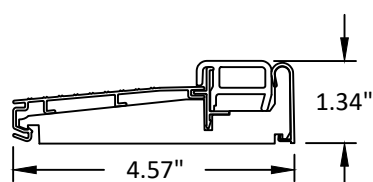

31 ENDURA ZOBL4565 SILL

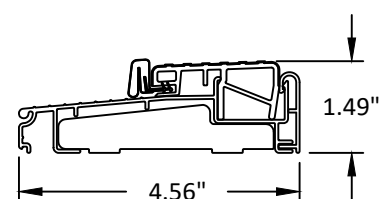

32 AFCO SIDELITE BASE

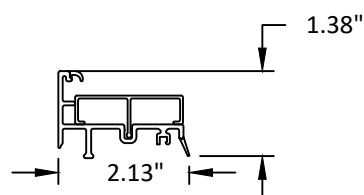

33 ENDURA SIDELITE BASE

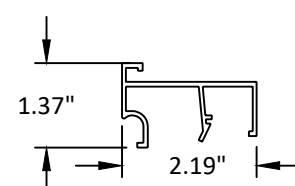

34 ENDURA ULTIMATE HURRICANE ASTRAGAL

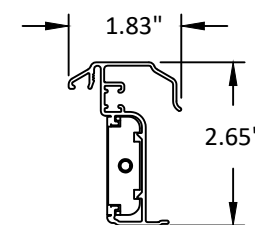

35 ENDURA ULTIMATE PUSH BUTTON ASTRAGAL

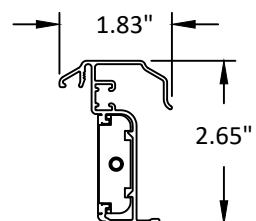

36 PLASTPRO MULLION

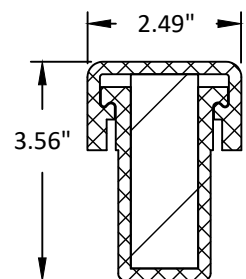

37 WOOD PINE MULLION

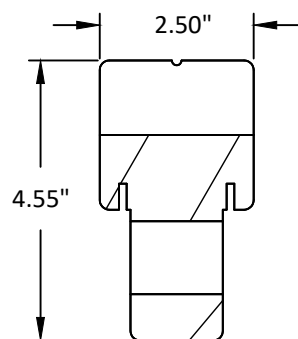

38 ENDURA FRAME SAVER MULLION

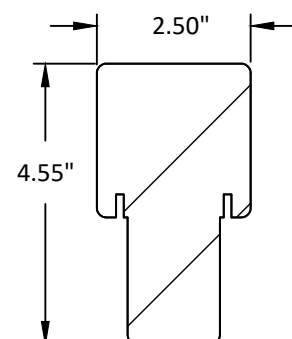

215 EAST ROOSEVELT AVE.
ZEELAND, MICHIGAN 49464

PH: (800) 253-3900

TITLE: INSWING & OUTSWING GLAZED FIBERGLASS DOOR (NON-HVHZ) (NON-IMPACT)

COMPONENTS

PREPARED BY: BUILDING DROPS, INC.
1900 NE MIAMI CT., SUITE 2-15
MIAMI, FL 33132
PH: (954) 399-8478
FAX: (954) 744-4738
WEB: www.buildingdrops.com



REMARKS	BY	DATE

THE INSTALLATION DETAILS DESCRIBED HEREIN ARE GENERIC AND MAY NOT REFLECT ACTUAL CONDITIONS FOR A SPECIFIC SITE. IF SITE CONDITIONS CAUSE INSTALLATION TO DEVIATE FROM THE REQUIREMENTS DETAILED HEREIN, A LICENSED ENGINEER OR ARCHITECT SHALL PREPARE SITE SPECIFIC DOCUMENTS FOR USE WITH THIS DOCUMENT.

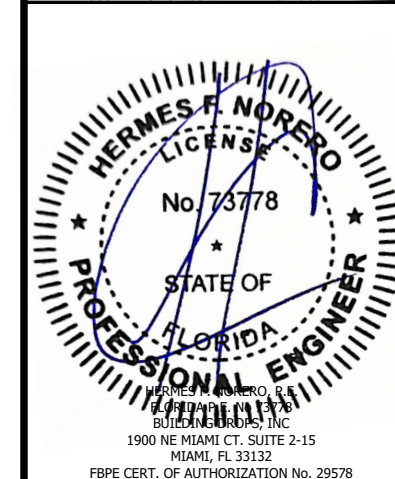

FL #:	FL47925
DATE:	12.01.2025
DWG. BY:	JR
CHK. BY:	HFN
SCALE:	NTS
DWG. #:	ODL012
SHEET:	25
	OF 25